



BLUE BOOK

British Standard version

Fire resisting ductwork

tested to BS476 Part 24

3rd Edition

(Volume 2 of 3 – product data sheets)

FLAMEBAR BW11

1. Type of Ductwork System

- Galvanised sheet steel duct, factory sprayed with Flamebar BW11.

3. Manufacturer

- Fire Protection Limited
- Flamebar House, South Road, Templefields, Harlow, Essex, CM20 2AR
- T: 01279 634230 F: 01279 634342 W: www.fireprotection.co.uk

7. Scope of use

- (1) Ventilation ductwork
- (2) Smoke extract ductwork
- (3) Kitchen extract ductwork

11. System Types & Cross Section available

- (a) Factory made systems (rectangular, circular, oval) Flamebar BW11 duct is constructed from galvanised sheet steel, manufactured to an enhanced standard then de-greased and factory fire sprayed with Flamebar BW11, which is a specially formulated water-based compound to achieve Stability and Integrity to BS 476 Part 24 and Insulation up to 400°C for over 4 hours.

13. Ductwork orientation

- (i) Horizontal ductwork
- (ii) Vertical ductwork

16. Duct wall/insulation thickness range

- BW11 – 0.7mm to 1.0mm.
- If additional insulation criteria is required, the product is overlaid with mineral wool, of varying thickness and varying densities, depending upon the insulation criteria.

19. Maximum Fire resistance to BS 476 Part 24

	Maximum duration (hrs)		
	Stability & Integrity	Insulation	Size
Fire Duct Type A + B	4	2	25 x 3m
Smoke Duct Type A + B	4	2	25 x 3m
Kitchen Extract Type A + B	4	1	25 x 3m
Pressurisation Type A	4	4	25 x 3m

- Flamebar BW11 duct is available in varying constructions for all pressure classes. The system is also available in flat, oval and circular sections – see the LPCB 3rd Party Accredited Certificate and the stamped and approved standard drawings within the BRE Assessment report for full details.

21. Fire Assessment Report Number

- CC88343

23. Appearance

- Standard off white, rippled effect, however a special order can be produced in any colour.

25. Third Party accreditation

- LPCB & FIRAS

27. Quality Assurance Approvals

- ISO 9001-2000

29. System durability

- Impact test to BS5669, in which a dart imparts 44.15 joules (32.5ft pound force) at maximum drop, resulting in a small indentation which passes under the criteria of BS5669. Flamebar BW11 Fire Duct also has undergone impact testing to the requirements of Appendix A BS5588 Part 5.

31. Other ductwork applications not addressed above

- Ceilings, service ducts, fire rated enclosures.
-

TABLE 1

System Name: **Flamebar BW11**
 Supply company name: **Fire Protection Limited**
 Fire resisting duct - scope of use / type: **VENTILATING DUCT**
 Fire Assessment Report number: **CC88343 dated 09/02/2004**
 Confirm that Ductwork system was tested & evaluated to BS 476 Part 24 [ISO 6944]: **YES**

ORIENTATION: Data for: horizontal and vertical duct applications												
DUCT SHAPE: Data for: rectangular ducts and circular ducts and oval ducts												
Fire resistance [a] stability [b] integrity [c] insulation	Longer side or diameter	Thickness of duct [a] steel [b] board [c] coating	State if any panel stiffening is required	Max duct section length	State type of cross joints, section type & size	Max Spacing of duct stiffeners	Section type & size of duct stiffeners	Are stiffeners or tie rods needed?	Maximum spacing of hangers and bearers	Thickness of fire protection layer	Fire protection material type & product name	Fixing method for fire protection layers
(mins)	(mm)	(mm)	(yes/no)	(mm)	(mm)	(mm)	(mm)	(yes/no)	(mm)	(mm)		
a. 240 mins b. 240 mins c. 240 mins (fire outside)	400mm	a. 0.6mm c. 0.7mm minimum	No	1510mm	20mm slide on or slip joint	N/A	N/A	No	1000mm	Up to 100mm (fire insulation)	Flamebar BW11 plus mineral fibre (when required)	Pin fix
120 mins (fire inside)	1000mm	a. 0.8mm c. 0.7mm minimum	No	1510mm	40mm slide on	1000mm	40 x 4 RSA	No	1000mm	Up to 100mm (fire insulation)	Flamebar BW11 plus mineral fibre (when required)	Pin fix
	3000mm	a. 1.2mm c. 0.7mm minimum	No	1485mm	50 x 5 RSA	500mm	60 x 6 RSA	Yes – tie rods	1000mm	Up to 100mm (fire insulation)	Flamebar BW11 plus mineral fibre (when required)	Pin fix

NOTES

Base material of the primary duct – Galvanised steel or stainless steel.
 Cross joint fixings – centres/seals and gaskets required - Maximum 400mm centres, Flamebar Intumescent Gasket and Flamebar Intumescent Sealant (if required, depending upon pressure requirements).
 Longitudinal joints – corner type / size / fixings / sealing: RAS or Pittsburgh lock and Flamebar Intumescent Sealant
 Additional non fire protecting layers to the duct – specify material type, application method, thickness and fixings-N/A
 Detail of seal at duct penetration through fire resisting walls or floors - See detail below
 DRAWINGS – See details below.

CONSTRUCTION FOR ADDITIONAL INFORMATION AND ALTERNATIVE FIRE DUCT CONSTRUCTION METHODS, SEE OUR BRE APPROVED STANDARDS STD200-STD350				INSTALLATION METHOD FOR VARIOUS INSULATION INSTALLATIONS. SEE OUR BRE APPROVED STANDARDS STD1032-STD1054	
 <p>PITTSBURGH LOCK SEAM FLAMEBAR BW11 FLAMEBAR SEALANT.</p>	 <p>ROLLED STEEL ANGLE FLANGED JOINT FLAMEBAR INTUMESCENT GASKET FLAMEBAR BW11 FASTENING FASTENING EITHER 8mm TURN UP OR SEAL TOE OF ANGLE</p>	 <p>GF1000 MORTAR FLANGE 50 MAX. OR WITHIN WALL TYPICAL WALL PENETRATION SEAL.</p>	 <p>CALCIUM SULCATE BOARD SPREADER PLATE SUPPORT DETAIL FOR LAGGED DUCT</p>	 <p>INSULATION JOINT DROP ROD REBARBED INSULATION SLAB TO COVER FLANGE AND STIFFENERS CALCIUM SULCATE BOARD STIFFENER SPREADER PLATE BEARER INSULATION PINS SECTION THROUGH DUCT</p>	

TABLE 2

System Name: **Flamebar BW11**
 Supply company name: **Fire Protection Limited**
 Fire resisting duct - scope of use / type: **VENTILATING DUCT**
 Fire Assessment Report number: **CC88343 dated 09/02/2004**
 Confirm that Ductwork system was tested & evaluated to BS 476 Part 24 [ISO 6944]: **YES**

ORIENTATION: Data for: horizontal and vertical duct applications												
DUCT SHAPE: Data for: rectangular ducts and circular ducts and oval ducts												
Fire resistance [a] stability [b] integrity [c] insulation	Longer side or diameter	Thickness of duct [a] steel [b] board [c] coating	State if any panel stiffening is required	Max duct section length	State type of cross joints, section type & size	Max Spacing of duct stiffeners	Section type & size of duct stiffeners	Are stiffeners or tie rods needed?	Maximum spacing of hangers and bearers	Thickness of fire protection layer	Fire protection material type & product name	Fixing method for fire protection layers
(mins)	(mm)	(mm)	(yes/no)	(mm)	(mm)	(mm)	(mm)	(yes/no)	(mm)	(mm)		
a. 120 mins b. 120 mins c. 120 mins	400mm	a. 0.6mm c. 0.7mm minimum	No	1510mm	20mm slide on or slip joint	N/A	N/A	No	1500mm	Up to 100mm (fire insulation)	Flamebar BW11 plus mineral fibre (when required)	Pin fix
(fire outside)	1000mm	a. 0.8mm c. 0.7mm minimum	No	1510mm	40mm slide on	1000mm	40 x 4 RSA	No	1500mm	Up to 100mm (fire insulation)	Flamebar BW11 plus mineral fibre (when required)	Pin fix
120 mins (fire inside)	3000mm	a. 1.2mm c. 0.7mm minimum	No	1485mm	50 x 5 RSA	500mm	60 x 6 RSA	Yes – tie rods	1500mm	Up to 100mm (fire insulation)	Flamebar BW11 plus mineral fibre (when required)	Pin fix

NOTES

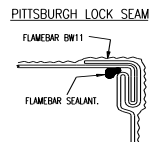
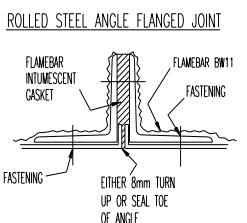
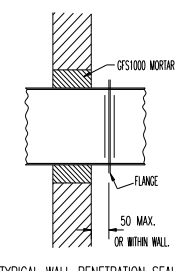
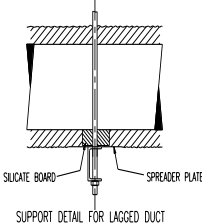
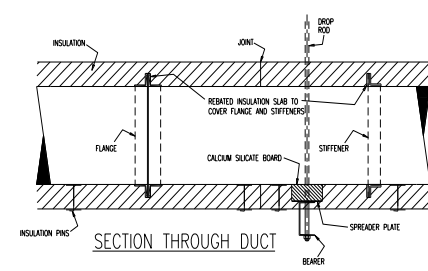
1. Base material of the primary duct – Galvanised steel or stainless steel.
2. Cross joint fixings – centres/seals and gaskets required - Maximum 400mm centres, Flamebar Intumescent Gasket and Flamebar Intumescent Sealant (if required, depending upon pressure requirements).
3. Longitudinal joints – corner type / size / fixings / sealing: RAS or Pittsburgh lock and Flamebar Intumescent Sealant
4. Additional non fire protecting layers to the duct – specify material type, application method, thickness and fixings-N/A
5. Detail of seal at duct penetration through fire resisting walls or floors - See detail below

DRAWINGS – See details below

CONSTRUCTION FOR ADDITIONAL INFORMATION AND ALTERNATIVE FIRE DUCT CONSTRUCTION METHODS. SEE OUR BRE APPROVED STANDARDS STD200-STD350					INSTALLATION METHOD FOR VARIOUS INSULATION INSTALLATIONS. SEE OUR BRE APPROVED STANDARDS STD1032-STD1054	
 <p>PITTSBURGH LOCK SEAM FLAMEBAR BW11 FLAMEBAR SEALANT.</p>	 <p>TIE ROD DETAILS STEEL WASHER FLAMEBAR BW11 DUCT MINIMUM WIRE ROD</p>	 <p>ROLLED STEEL ANGLE FLANGED JOINT FLAMEBAR INTUMESCENT GASKET FLAMEBAR BW11 FASTENING FASTENING EITHER 8mm TURN UP OR SEAL TOE OF ANGLE</p>	 <p>TYPICAL WALL PENETRATION SEAL CF5000 MORTAR FLANGE 50 MAX. OR WITHIN WALL.</p>	 <p>SUPPORT DETAIL FOR LAGGED DUCT CALCIUM SILICATE BOARD SPREADER PLATE</p>	 <p>SECTION THROUGH DUCT INSULATION JOINT DROP ROD RESINATED INSULATION SLAB TO COVER FLANGE AND STIFFENERS CALCIUM SILICATE BOARD STIFFENER SPREADER PLATE INSULATION PINS BEARER</p>	

TABLE 3

System Name: **Flamebar BW11**
 Supply company name: **Fire Protection Limited**
 Fire resisting duct - scope of use / type: **SMOKE EXTRACT DUCT**
 Fire Assessment Report number: **CC88343 dated 09/02/2004**
 Confirm that Ductwork system was tested & evaluated to BS 476 Part 24 [ISO 6944]: **YES**

ORIENTATION: Data for: horizontal and vertical duct applications												
DUCT SHAPE: Data for: rectangular ducts and circular ducts and oval ducts												
Fire resistance [a] stability [b] integrity [c] insulation	Longer side or diameter	Thickness of duct [a] steel [b] board [c] coating	State if any panel stiffening is required	Max duct section length	State type of cross joints, section type & size	Max Spacing of duct stiffeners	Section type & size of duct stiffeners	Are stiffeners or tie rods needed?	Maximum spacing of hangers and bearers	Thickness of fire protection layer	Fire protection material type & product name	Fixing method for fire protection layers
(mins)	(mm)	(mm)	(yes/no)	(mm)	(mm)	(mm)	(mm)	(yes/no)	(mm)	(mm)		
a. 240 mins b. 240 mins c. 240 mins (fire outside)	400mm	a. 0.6mm c. 0.7mm minimum	No	1510mm	20mm slide on or slip joint	N/A	N/A	No	1000mm	Up to 100mm (fire insulation)	Flamebar BW11 plus mineral fibre (when required)	Pin fix
120 mins (fire inside)	1000mm	a. 0.8mm c. 0.7mm minimum	No	1510mm	40mm slide on	1000mm	40 x 4 RSA	No	1000mm	Up to 100mm (fire insulation)	Flamebar BW11 plus mineral fibre (when required)	Pin fix
	3000mm	a. 1.2mm c. 0.7mm minimum	No	1485mm	50 x 5 RSA	500mm	60 x 6 RSA	Yes – tie rods	1000mm	Up to 100mm (fire insulation)	Flamebar BW11 plus mineral fibre (when required)	Pin fix

NOTES

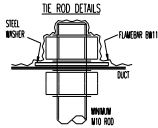
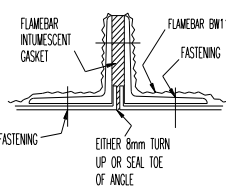
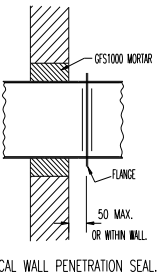
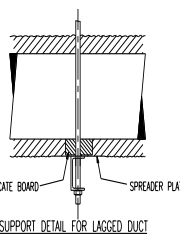
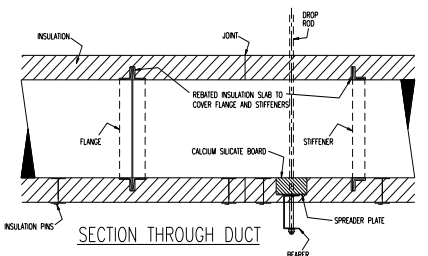
1. Base material of the primary duct – Galvanised steel or stainless steel.
2. Cross joint fixings – centres/seals and gaskets required - Maximum 400mm centres, Flamebar Intumescent Gasket and Flamebar Intumescent Sealant (if required, depending upon pressure requirements).
3. Longitudinal joints – corner type / size / fixings / sealing: RAS or Pittsburgh lock and Flamebar Intumescent Sealant
4. Additional non fire protecting layers to the duct – specify material type, application method, thickness and fixings-N/A
5. Detail of seal at duct penetration through fire resisting walls or floors - See detail below
6. DRAWINGS – See details below

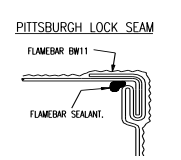
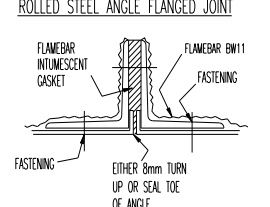
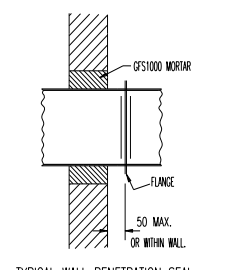
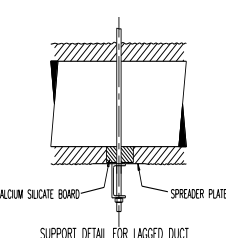
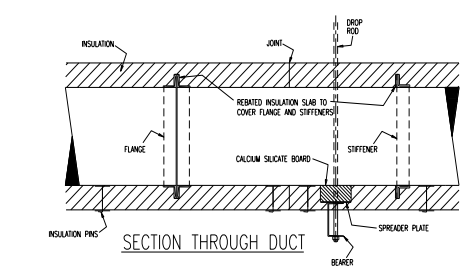
CONSTRUCTION FOR ADDITIONAL INFORMATION AND ALTERNATIVE FIRE DUCT CONSTRUCTION METHODS, SEE OUR BRE APPROVED STANDARDS STD200-STD350				INSTALLATION METHOD FOR VARIOUS INSULATION INSTALLATIONS. SEE OUR BRE APPROVED STANDARDS STD1032-STD1054
 <p>PITTSBURGH LOCK SEAM</p>	 <p>ROLLED STEEL ANGLE FLANGED JOINT</p>	 <p>TYPICAL WALL PENETRATION SEAL</p>	 <p>SUPPORT DETAIL FOR LAGGED DUCT</p>	 <p>SECTION THROUGH DUCT</p>

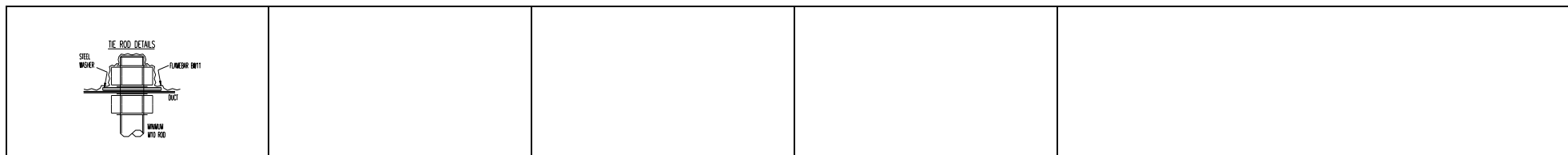

TABLE 4

System Name: **Flamebar BW11**
 Supply company name: **Fire Protection Limited**
 Fire resisting duct - scope of use / type: **SMOKE EXTRACT DUCT**
 Fire Assessment Report number: **CC88343 dated 09/02/2004**
 Confirm that Ductwork system was tested & evaluated to BS 476 Part 24 [ISO 6944]: **YES**

ORIENTATION: Data for: horizontal and vertical duct applications												
DUCT SHAPE: Data for: rectangular ducts and circular ducts and oval ducts												
Fire resistance [a] stability [b] integrity [c] insulation	Longer side or diameter	Thickness of duct [a] steel [b] board [c] coating	State if any panel stiffening is required	Max duct section length	State type of cross joints, section type & size	Max Spacing of duct stiffeners	Section type & size of duct stiffeners	Are stiffeners or tie rods needed?	Maximum spacing of hangers and bearers	Thickness of fire protection layer	Fire protection material type & product name	Fixing method for fire protection layers
(mins)	(mm)	(mm)	(yes/no)	(mm)	(mm)	(mm)	(mm)	(yes/no)	(mm)	(mm)		
a. 120 mins b. 120 mins c. 120 mins (fire outside)	400mm	a. 0.6mm c. 0.7mm minimum	No	1510mm	20mm slide on or slip joint	N/A	N/A	No	1500mm	Up to 100mm (fire insulation)	Flamebar BW11 plus mineral fibre (when required)	Pin fix
120 mins (fire inside)	1000mm	a. 0.8mm c. 0.7mm minimum	No	1510mm	40mm slide on	1000mm	40 x 4 RSA	No	1500mm	Up to 100mm (fire insulation)	Flamebar BW11 plus mineral fibre (when required)	Pin fix
	3000mm	a. 1.2mm c. 0.7mm minimum	No	1485mm	50 x 5 RSA	500mm	60 x 6 RSA	Yes – tie rods	1500mm	Up to 100mm (fire insulation)	Flamebar BW11 plus mineral fibre (when required)	Pin fix

NOTES

1. Base material of the primary duct – Galvanised steel or stainless steel.
2. Cross joint fixings – centres/seals and gaskets required - Maximum 400mm centres, Flamebar Intumescent Gasket and Flamebar Intumescent Sealant (if required, depending upon pressure requirements).
3. Longitudinal joints – corner type / size / fixings / sealing: RAS or Pittsburgh lock and Flamebar Intumescent Sealant
4. Additional non fire protecting layers to the duct – specify material type, application method, thickness and fixings-N/A
5. Detail of seal at duct penetration through fire resisting walls or floors - See detail below
6. DRAWINGS – See details below.

CONSTRUCTION FOR ADDITIONAL INFORMATION AND ALTERNATIVE FIRE DUCT CONSTRUCTION METHODS, SEE OUR BRE APPROVED STANDARDS STD200-STD350	INSTALLATION METHOD FOR VARIOUS INSULATION INSTALLATIONS. SEE OUR BRE APPROVED STANDARDS STD1032-STD1054
---	---

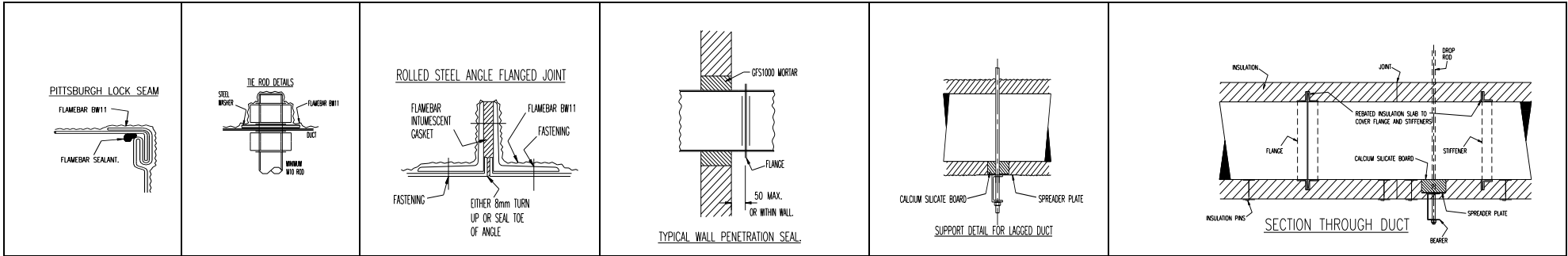

TABLE 5

System Name: **Flamebar BW11**
 Supply company name: **Fire Protection Limited**
 Fire resisting duct - scope of use / type: **KITCHEN EXTRACT DUCT**
 Fire Assessment Report number: **CC88343 dated 09/02/2004**
 Confirm that Ductwork system was tested & evaluated to BS 476 Part 24 [ISO 6944]: **YES**

ORIENTATION: Data for: horizontal and vertical duct applications												
DUCT SHAPE: Data for: rectangular ducts and circular ducts and oval ducts												
Fire resistance [a] stability [b] integrity [c] insulation	Longer side or diameter	Thickness of duct [a] steel [b] board [c] coating	State if any panel stiffening is required	Max duct section length	State type of cross joints, section type & size	Max Spacing of duct stiffeners	Section type & size of duct stiffeners	Are stiffeners or tie rods needed?	Maximum spacing of hangers and bearers	Thickness of fire protection layer	Fire protection material type & product name	Fixing method for fire protection layers
(mins)	(mm)	(mm)	(yes/no)	(mm)	(mm)	(mm)	(mm)	(yes/no)	(mm)	(mm)		
a. 240 mins b. 240 mins c. 60 mins (fire outside) 120 mins (fire inside)	400mm	a. 0.6mm c. 0.7mm minimum	No	1510mm	20mm slide on or slip joint	N/A	N/A	No	1000mm	Up to 100mm (fire insulation)	Flamebar BW11 plus mineral fibre (when required)	Pin fix
	1000mm	a. 0.8mm c. 0.7mm minimum	No	1510mm	40mm slide on	1000mm	40 x 4 RSA	No	1000mm	Up to 100mm (fire insulation)	Flamebar BW11 plus mineral fibre (when required)	Pin fix
	3000mm	a. 1.2mm c. 0.7mm minimum	No	1485mm	50 x 5 RSA	500mm	60 x 6 RSA	Yes – tie rods	1000mm	Up to 100mm (fire insulation)	Flamebar BW11 plus mineral fibre (when required)	Pin fix

NOTES

1. Base material of the primary duct – Galvanised steel or stainless steel.
2. Cross joint fixings – centres/seals and gaskets required - Maximum 400mm centres, Flamebar Intumescent Gasket and Flamebar Intumescent Sealant (if required, depending upon pressure requirements).
3. Longitudinal joints – corner type / size / fixings / sealing: RAS or Pittsburgh lock and Flamebar Intumescent Sealant
4. Additional non fire protecting layers to the duct – specify material type, application method, thickness and fixings-N/A
5. Detail of seal at duct penetration through fire resisting walls or floors - See detail below
6. DRAWINGS – See details below

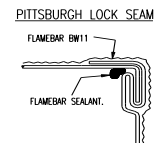
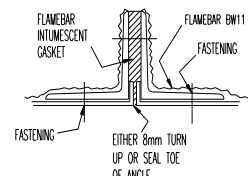
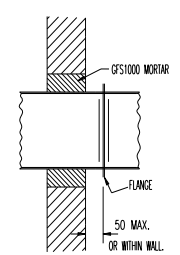
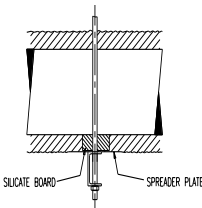
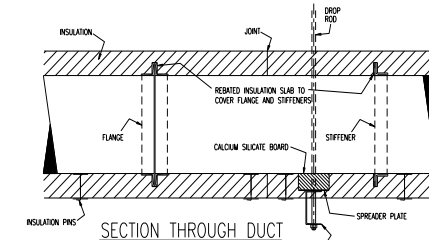
<p>CONSTRUCTION FOR ADDITIONAL INFORMATION AND ALTERNATIVE FIRE DUCT CONSTRUCTION METHODS, SEE OUR BRE APPROVED STANDARDS STD200-STD350</p>			<p>INSTALLATION METHOD FOR VARIOUS INSULATION INSTALLATIONS. SEE OUR BRE APPROVED STANDARDS STD1032-STD1054</p>				
 <p>PITTSBURGH LOCK SEAM FLAMEBAR BW11 FLAMEBAR SEALANT.</p>	 <p>ROLLED STEEL ANGLE FLANGED JOINT FLAMEBAR INTUMESCENT GASKET FASTENING FASTENING EITHER 8mm TURN UP OR SEAL TOE OF ANGLE</p>	 <p>GFS1000 MORTAR FLANGE 50 MAX. OR WITHIN WALL. TYPICAL WALL PENETRATION SEAL.</p>	 <p>CALCIUM SILICATE BOARD SPREADER PLATE SUPPORT DETAIL FOR LAGGED DUCT</p>	 <p>INSULATION JOINT DROP ROD REBATED INSULATION SLAB TO COVER FLANGE AND STIFFENER FLANGE CALCIUM SILICATE BOARD STIFFENER INSULATION PINS SECTION THROUGH DUCT SPREADER PLATE BEARER</p>			

				
---	--	--	--	--

TABLE 6

System Name: **Flamebar BW11**
 Supply company name: **Fire Protection Limited**
 Fire resisting duct - scope of use / type: **KITCHEN EXTRACT DUCT**
 Fire Assessment Report number: **CC88343 dated 09/02/2004**
 Confirm that Ductwork system was tested & evaluated to BS 476 Part 24 [ISO 6944]: **YES**

ORIENTATION: Data for: horizontal and vertical duct applications												
DUCT SHAPE: Data for: rectangular ducts and circular ducts and oval ducts												
Fire resistance [a] stability [b] integrity [c] insulation	Longer side or diameter	Thickness of duct [a] steel [b] board [c] coating	State if any panel stiffening is required	Max duct section length	State type of cross joints, section type & size	Max Spacing of duct stiffeners	Section type & size of duct stiffeners	Are stiffeners or tie rods needed?	Maximum spacing of hangers and bearers	Thickness of fire protection layer	Fire protection material type & product name	Fixing method for fire protection layers
(mins)	(mm)	(mm)	(yes/no)	(mm)	(mm)	(mm)	(mm)	(yes/no)	(mm)	(mm)		
a. 120 mins b. 120 mins c. 120 mins (fire outside)	400mm	a. 0.6mm c. 0.7mm minimum	No	1510mm	20mm slide on or slip joint	N/A	N/A	No	1500mm	Up to 100mm (fire insulation)	Flamebar BW11 plus mineral fibre (when required)	Pin fix
120 mins (fire inside)	1000mm	a. 0.8mm c. 0.7mm minimum	No	1510mm	40mm slide on	1000mm	40 x 4 RSA	No	1500mm	Up to 100mm (fire insulation)	Flamebar BW11 plus mineral fibre (when required)	Pin fix
	3000mm	a. 1.2mm c. 0.7mm minimum	No	1485mm	50 x 5 RSA	500mm	60 x 6 RSA	Yes – tie rods	1500mm	Up to 100mm (fire insulation)	Flamebar BW11 plus mineral fibre (when required)	Pin fix

NOTES

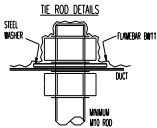
1. Base material of the primary duct – Galvanised steel or stainless steel.
2. Cross joint fixings – centres/seals and gaskets required - Maximum 400mm centres, Flamebar Intumescent Gasket and Flamebar Intumescent Sealant (if required, depending upon pressure requirements).
3. Longitudinal joints – corner type / size / fixings / sealing: RAS or Pittsburgh lock and Flamebar Intumescent Sealant
4. Additional non fire protecting layers to the duct – specify material type, application method, thickness and fixings-N/A
5. Detail of seal at duct penetration through fire resisting walls or floors - See detail below
6. DRAWINGS – See details below

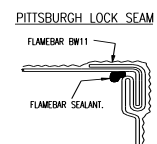
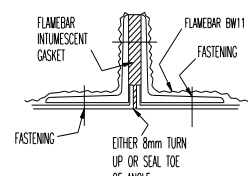
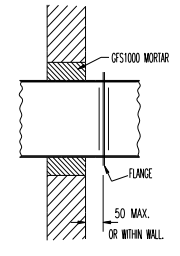
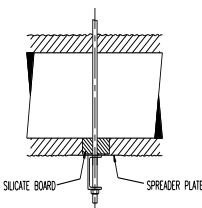
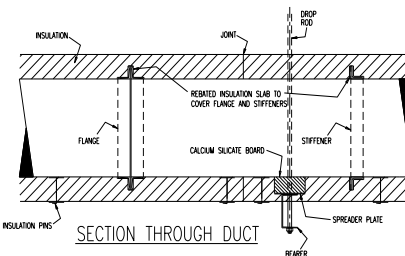
CONSTRUCTION FOR ADDITIONAL INFORMATION AND ALTERNATIVE FIRE DUCT CONSTRUCTION METHODS, SEE OUR BRE APPROVED STANDARDS STD200-STD350				INSTALLATION METHOD FOR VARIOUS INSULATION INSTALLATIONS. SEE OUR BRE APPROVED STANDARDS STD1032-STD1054	
 <p>PITTSBURGH LOCK SEAM FLAMEBAR BW11 FLAMEBAR SEALANT.</p>	 <p>ROLLED STEEL ANGLE FLANGED JOINT FLAMEBAR INTUMESCENT GASKET FLAMEBAR BW11 FASTENING FASTENING EITHER 8mm TURN UP OR SEAL TOE OF ANGLE</p>	 <p>TYPICAL WALL PENETRATION SEAL GFS1000 MORTAR FLANGE 50 MAX. OR WITHIN WALL.</p>	 <p>SUPPORT DETAIL FOR LAGGED DUCT CALCIUM SILICATE BOARD SPREADER PLATE</p>	 <p>SECTION THROUGH DUCT INSULATION JOINT DROP ROD STIFFENER SPREADER PLATE BEARER INSULATION PINS FLANGE CALCIUM SILICATE BOARD REBATED INSULATION SLAB TO COVER FLANGE AND STIFFENER</p>	

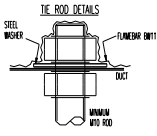
				
---	--	--	--	--

Promat DURADUCT® LT (Durasteel duct system)

1. **Type of ductwork system**
 2. Promat DURADUCT® LT is a factory fabricated duct system with an enhanced galvanised steel inner, over boarded with 6mm Durasteel and proprietary flange system.
3. **Manufacturer / Supplier to the market / Preferred supplier**
 4. Licensed fabricators of Promat UK Ltd
 5. The Sterling Centre, Eastern Road, Bracknell, Berkshire RG12 2TD
 - Tel: 01344 381 400 Fax: 01344 381 401
 - e-mail: technical@promat.co.uk Web: www.promat.co.uk
6. **Scope of use**
 7. Ventilation Ductwork (Natural and Powered)
 - Smoke Extract Ductwork
 - Kitchen Extract Ductwork
8. **System types & cross section available**
 9. Addition of insulation encasement required for fire-insulated ducts. Rectangular ducts only
10. **Ductwork orientation**
 11. Horizontal
 - Vertical
12. **Duct wall / Insulation thickness range**
 13. Promat DURADUCT® LT 7.5mm / Rock wool insulation 0 – 120mm
14. **Nominal board density**
 15. Density N/A - Durasteel sheet weight = 16.8kg/m²
16. **Maximum fire resistance to BS 476: Part 24**
 17. up to 240min Stability, Integrity and Insulation
18. **Fire Assessment Report Number:**
 19. WFR No. C126658H
20. **Third party accreditation**
 21. Certifire Certificate of Approval No CF 480
22. **Quality assurance approvals**
 23. Production surveillance under BS EN ISO 9001:2000
24. **Product appearance**
 25. Distinctive dimpled galvanised steel faced composite, with fibre cement core
26. **Other applications**
 27. Mechanical and electrical services enclosures
 - 28.
 - 29.
 - 30.
 - 31.

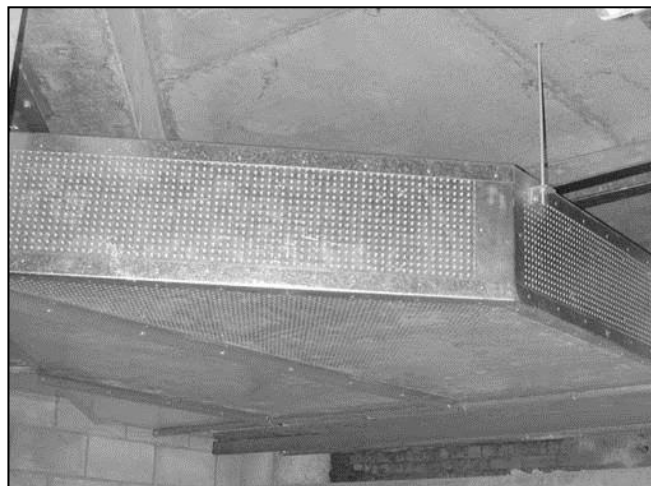

TABLE 1

System Name:

Promat DURADUCT® LT Ductwork System

Supply company name:

Licensed fabricators of Promat UK Ltd

Fire resisting duct - scope of use / type:

VENTILATION & SMOKE EXTRACT DUCTS

Fire Assessment Report number:

WFRC No. C126658H dated: 29th January 2003

Confirm that Ductwork system was tested & evaluated to BS 476 Part 24 [ISO 6944:1985]: Yes

ORIENTATION: Data for Horizontal Duct Applications												
DUCT SHAPE: Data for Rectangular Ducts												
Fire resistance stability integrity insulation	Maximum Duct Size (width x height)	Thickness of duct (DURADUCT® LT)	State if any panel stiffening is required	Max duct section length	State type of cross joints, section type & size	Max Spacing of duct stiffeners	Section type & size of duct stiffeners	Are stiffeners or tie rods needed ?	Maximum spacing of hangers and bearers	Thickness of fire protection layer	Fire protection material type & product name	Fixing method for fire protection layers note 4
(minutes)	(m x m)	(mm)	(yes/no)	(m)	(mm)	(m)	(mm)	(yes/no)	(m)	(mm)		
60 / 60 / 60	6.0 x 2.0	note 1	no	1.5	note 2	1.5	threaded rod	note 3	1.5	1 x 50	rock wool 60kg/m ³	pin fix
120 / 120 / 120	6.0 x 2.0	note 1	no	1.5	note 2	1.5	threaded rod	note 3	1.5	2 x 40	rock wool 140kg/m ³	pin fix
240 / 240 / 240	6.0 x 2.0	note 1	no	1.5	note 2	1.5	threaded rod	note 3	1.5	3 x 40	rock wool 140kg/m ³	pin fix
240 / 240 / -	6.0 x 2.0	note 1	no	1.5	note 2	1.5	threaded rod	note 3	1.5	not required	-	-

Note 1 - DURADUCT® LT is a factory assembled modular duct system, constructed with a single layer of 6mm DURASTEEL® boards (maximum board size 2500mm x 1200mm) that is lined with a galvanised steel inner sheet, minimum 0.8mm thick.

Note 2 - The ducts are finished with 50mm x 50mm x 1mm corner trim and use a proprietary steel flange system. Flange connections are sealed using PROMASEAL® Intumescent Sealant and fastened with M10 bolts at the corners and steel flange clamps at maximum 450mm centres. 40mm x 40mm x 3mm angle may be used as an alternative to the proprietary flange sections. The maximum module length is 1500mm for ducts up to 1200mm wide or 1210mm long for ducts of larger widths.

Note 3 - Where ducts exceed 1.5m in width, intermediate threaded rods that pass through the duct and support both the bearer under and the upper wall of the duct are required (at maximum 1.5m centres). All penetrations are sealed.

Note 4 - Rock wool insulation, where required, is fastened to the outside of the ducts using 2.5mm stud welded pins and 38mm spring steel washers in a maximum 400mm x 400mm grid pattern. Rock wool cover strips are also used at duct flanges. Other conditions may apply.

The duct hangers consist of threaded steel drop rods and steel angle or channels bearers. The rods and angles must be sized to ensure that the permitted stresses in Section 6 of this guidance document are not exceeded.

3-sided, 2-sided and 1-sided duct systems are fastened to longitudinal corner angle fitted to the soffit of the concrete floor or concrete/masonry wall. Where ducts exceed 1.5m in width, intermediate threaded rods are required, in the same way as for 4-sided ducts.

At the penetration through fire compartment walls, a collar of rock wool, at least 300mm wide is bonded around the duct on both sides of the penetration on top of the general rock wool insulation. DURAFIRE® AD proprietary access panels up to 600mm x 600mm, may be incorporated into the duct walls to provide up to 240minutes fire integrity.

TABLE 2

System Name:

Promat DURADUCT® LT Ductwork System

Supply company name:

Licensed fabricators of Promat UK Ltd

Fire resisting duct - scope of use / type:

KITCHEN EXTRACT DUCTS

Fire Assessment Report number:

WFRC No. C126658H dated: 29th January 2003

Confirm that Ductwork system was tested & evaluated to BS 476 Part 24 [ISO 6944:1985]: Yes

ORIENTATION: Data for Horizontal Duct Applications												
DUCT SHAPE: Data for Rectangular Ducts												
Fire resistance stability integrity insulation	Maximum Duct Size (width x height)	Thickness of duct (DURADUCT® LT)	State if any panel stiffening is required	Max duct section length	State type of cross joints, section type & size	Max Spacing of duct stiffeners	Section type & size of duct stiffeners	Are stiffeners or tie rods needed ?	Maximum spacing of hangers and bearers	Thickness of fire protection layer	Fire protection material type & product name	Fixing method for fire protection layers note 4
(minutes)	(m x m)	(mm)	(yes/no)	(m)	(mm)	(m)	(mm)	(yes/no)	(m)	(mm)		
60 / 60 / 60	6.0 x 2.0	note 1	no	1.5	note 2	1.5	threaded rod	note 3	1.5	1 x 50	rock wool 165kg/m ³	pin fix
120 / 120 / 120	6.0 x 2.0	note 1	no	1.5	note 2	1.5	threaded rod	note 3	1.5	2 x 40	rock wool 165kg/m ³	pin fix

Note 1 - DURADUCT® LT is a factory assembled modular duct system, constructed with a single layer of 6mm DURASTEEL® boards (maximum board size 2500mm x 1200mm) that is lined with a galvanised steel inner sheet, minimum 0.8mm thick.

Note 2 - The ducts are finished with 50mm x 50mm x 1mm corner trim and use a proprietary steel flange system. Flange connections are sealed using PROMASEAL® Intumescent Sealant and fastened with M10 bolts at the corners and steel flange clamps at maximum 450mm centres. 40mm x 40mm x 3mm angle may be used as an alternative to the proprietary flange sections. The maximum module length is 1500mm for ducts up to 1200mm wide or 1210mm long for ducts of larger widths.

Note 3 - Where ducts exceed 1.5m in width, intermediate threaded rods that pass through the duct and support both the bearer under and the upper wall of the duct are required (at maximum 1.5m centres). All penetrations are sealed.

Note 4 - Rock wool insulation is fastened to the outside of the ducts using 2.5mm stud welded pins and 38mm spring steel washers in a maximum 400mm x 400mm grid pattern. Rock wool cover strips are also used at duct flanges. Other conditions may apply.

The duct hangers consist of threaded steel drop rods and steel angle or channels bearers. The rods and angles must be sized to ensure that the permitted stresses in Section 6 of this guidance document are not exceeded.

3-sided, 2-sided and 1-sided duct systems are fastened to longitudinal corner angle fitted to the soffit of the concrete floor or concrete/masonry wall. Where ducts exceed 1.5m in width, intermediate threaded rods are required, in the same way as for 4-sided ducts.

At the penetration through fire compartment walls, a collar of rock wool, at least 300mm wide is bonded around the duct on both sides of the penetration on top of the general rock wool insulation.

DURAFIRE® AD proprietary access panels up to 600mm x 600mm, may be incorporated into the duct walls to provide up to 240minutes fire integrity.

Promat DURADUCT® SMT Fireblast (Durasteel duct system)

1. **Type of ductwork system**
 2. Promat DURADUCT® SMT is a robust site, or factory fabricated duct system, constructed from 9.5mm Durasteel fastened to welded or cleated prefabricated 3mm steel skeletal framework.
3. **Manufacturer / Supplier to the market / Preferred supplier**
 4. Licensed fabricators of Promat UK Ltd
 5. The Sterling Centre, Eastern Road, Bracknell, Berkshire RG12 2TD
Tel: 01344 381 400 Fax: 01344 381 401
e-mail: technical@promat.co.uk Web: www.promat.co.uk
6. **Scope of use**
 7. Blast Resistant Ductwork
 8. Ventilation Ductwork (Natural and Powered)
 9. Smoke Extract Ductwork
 10. Kitchen Extract Ductwork
11. **System types & cross section available**
 12. Addition of insulation encasement required for fire-insulated ducts. Rectangular ducts only
13. **Ductwork orientation**
 14. Horizontal
 15. Vertical
16. **Duct wall / Insulation thickness range**
 17. Promat DURADUCT® SMT 9.5mm / Rock wool insulation 0 – 120mm
18. **Nominal board density**
 19. Density N/A - Durasteel sheet weight = 21.0kg/m²
20. **Maximum fire resistance to BS 476: Part 24**
 21. up to 240min Stability, Integrity and Insulation
22. **Fire Assessment Report Number**
 23. WFRC No. C126658J & WFRC No. C126658L
24. **Third party accreditation**
 25. Certifire Certificate of Approval No CF 480
26. **Quality assurance approvals**
 27. Production surveillance under BS EN ISO 9001:2000
28. **Product appearance**
 29. Distinctive dimpled galvanised steel faced composite, with fibre cement core
30. **Other applications**
 31. Single and doubles doors
 32. Sliding doors
 33. Shutters and traps
 34. Security and blast doors
 35. Fire and blast barriers
 36. Mechanical and electrical services enclosures
 - 37.
 - 38.
 - 39.

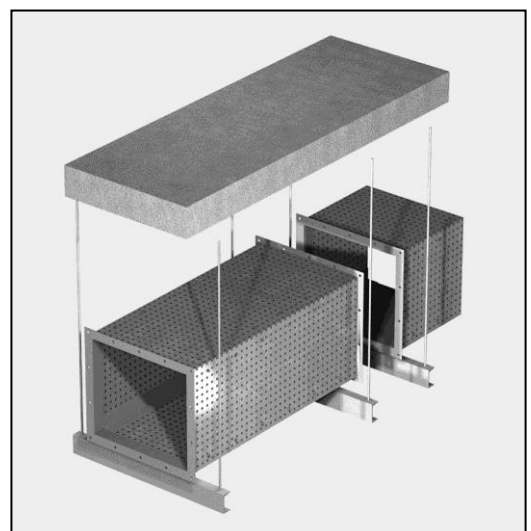

TABLE 1

System Name:

Promat DURADUCT® SMT FIREBLAST

Supply company name:

Licensed fabricators of Promat UK Ltd

Fire resisting duct - scope of use / type:

FIREBLAST, VENTILATION & SMOKE EXTRACT DUCTS

Fire Assessment Report number:

WFRC No. C126658J & WFRC No. C126658L dated: 29th January 2003

Confirm that Ductwork system was tested & evaluated to BS 476 Part 24 [ISO 6944:1985]: Yes

ORIENTATION: Data for Horizontal Duct Applications												
DUCT SHAPE: Data for Rectangular Ducts												
Fire resistance stability integrity insulation	Maximum Duct Size (width x height)	Thickness of duct (DURADUCT® SMT)	State if any panel stiffening is required	Max duct section length	State type of cross joints, section type & size	Max Spacing of duct stiffeners	Section type & size of duct stiffeners	Are stiffeners or tie rods needed ?	Maximum spacing of hangers and bearers	Thickness of fire protection layer	Fire protection material type & product name	Fixing method for fire protection layers note 4
(minutes)	(m x m)	(mm)	(yes/no)	(m)	(mm)	(m)	(mm)	(yes/no)	(m)	(mm)		
60 / 60 / 60	6.0 x 2.0	note 1	no	2.5	note 2	1.5	note 3	note 3	1.5	1 x 50	rock wool 60kg/m ³	pin fix
120 / 120 / 120	6.0 x 2.0	note 1	no	2.5	note 2	1.5	note 3	note 3	1.5	2 x 40	rock wool 140kg/m ³	pin fix
240 / 240 / 240	6.0 x 2.0	note 1	no	2.5	note 2	1.5	note 3	note 3	1.5	3 x 40	rock wool 140kg/m ³	pin fix
240 / 240 / -	6.0 x 2.0	note 1	no	2.5	note 2	1.5	note 3	note 3	1.5	Not required	-	-

Note 1 - The 4-sided DURADUCT® SMT duct system is constructed with a single layer of 9.5mm DURASTEEL® boards (maximum board size 2500mm x 1200mm).

Note 2 - The panels are supported by a welded or cleated framework of 50mm x 50mm x 3mm steel angles. The flanges of adjacent duct sections are fastened together with M8 bolts and sealed using Promaseal Intumescent Sealant. For factory assembled ducts the maximum module length is 1500mm.

Note 3 - The maximum spacing for hangers is 1500mm. Where ducts exceed this width, intermediate hangers are provided that pass through the duct and support both the bearer under, and the upper wall of the duct. All penetrations are sealed.

Note 4 - Rock wool insulation, where required is fastened to the outside of the ducts using 2.5mm stud welded pins and 38mm spring steel washers in a maximum 400mm x 400mm grid pattern. Rock wool cover strips are also used at duct flanges. Other conditions may apply.

3-sided, 2-sided and 1-sided duct systems are fastened to longitudinal corner angle fitted to the soffit of the concrete floor or concrete/masonry wall. Where ducts exceed 1.5m in width, intermediate threaded rods are required in the same way as for 4-sided ducts.

The hangers consist of threaded steel drop rods and steel angle or channels bearers. The rods and angles must be sized to ensure that the permitted stresses in Section 6 of this guidance document are not exceeded.

A duct joint must be positioned inline with compartment walls. The gaps between the duct and the reveals of the opening are filled with Durastop Original, 150mm thick.

The construction for Blast Resistant Ducts depend on the size and blast performance required.

DURAFIRE® AD proprietary access panels up to 600mm x 600mm, may be incorporated into the duct walls to provide up to 240minutes fire integrity.

TABLE 2

System Name:

Promat DURADUCT® SMT FIREBLAST

Supply company name:

Licensed fabricators of Promat UK Ltd

Fire resisting duct - scope of use / type:

KITCHEN EXTRACT DUCTS

Fire Assessment Report number:

WFRC No. C126658J & WFRC No. C126658L dated: 29th January 2003

Confirm that Ductwork system was tested & evaluated to BS 476 Part 24 [ISO 6944:1985]: Yes

ORIENTATION: Data for Horizontal Duct Applications												
DUCT SHAPE: Data for Rectangular Ducts												
Fire resistance stability integrity insulation	Maximum Duct Size (width x height)	Thickness of duct (DURADUCT® SMT)	State if any panel stiffening is required	Max duct section length	State type of cross joints, section type & size	Max Spacing of duct stiffeners	Section type & size of duct stiffeners	Are stiffeners or tie rods needed ?	Maximum spacing of hangers and bearers	Thickness of fire protection layer	Fire protection material type & product name	Fixing method for fire protection layers note 4
(minutes)	(m x m)	(mm)	(yes/no)	(m)	(mm)	(m)	(mm)	(yes/no)	(m)	(mm)		
60 / 60 / 60	6.0 x 2.0	note 1	no	2.5	note 2	1.5	note 3	note 3	1.5	1 x 50	rock wool 165kg/m ³	pin fix
120 / 120 / 120	6.0 x 2.0	note 1	no	2.5	note 2	1.5	note 3	note 3	1.5	2 x 40	rock wool 165kg/m ³	pin fix

Note 1 - The 4-sided DURADUCT® SMT duct system is constructed with a single layer of 9.5mm DURASTEEL® boards (maximum board size 2500mm x 1200mm).

Note 2 – The panels are supported by a welded or cleated framework of 50mm x 50mm x 3mm steel angles. The flanges of adjacent duct sections are fastened together with M8 bolts and sealed using Promaseal Intumescent Sealant. For factory assembled ducts the maximum module length is 1500mm.

Note 3 - The maximum spacing for hangers is 1500mm. Where ducts exceed this width, intermediate hangers are provided that pass through the duct and support both the bearer under, and the upper wall of the duct. All penetrations are sealed.

Note 4 - Rock wool insulation is fastened to the outside of the ducts using 2.5mm stud welded pins and 38mm spring steel washers in a maximum 400mm x 400mm grid pattern. Rock wool cover strips are also used at duct flanges. Other conditions may apply.

3-sided, 2-sided and 1-sided duct systems are fastened to longitudinal corner angle fitted to the soffit of the concrete floor or concrete/masonry wall. Where ducts exceed 1.5m in width, intermediate threaded rods are required in the same way as for 4-sided ducts.

The hangers consist of threaded steel drop rods and steel angle or channels bearers. The rods and angles must be sized to ensure that the permitted stresses in Section 6 of this guidance document are not exceeded.

A duct joint must be positioned inline with compartment walls. The gaps between the duct and the reveals of the opening are filled with Durastop Original, 150mm thick.

The construction for Blast Resistant Ducts depend on the size and blast performance required.

DURAFIRE® AD proprietary access panels up to 600mm x 600mm, may be incorporated into the duct walls to provide up to 240minutes fire integrity.

Promat DURADUCT® SR (Steel run-out ducting)

1. **Type of ductwork system**
 2. Promat DURADUCT® SR is an enhanced steel duct system for use with the Promat DD/SMT and the Promat DD/LT ranges, for the connection between the main smoke extract system and grilles where fire insulation is not required.
3. **Manufacturer / Supplier to the market / Preferred supplier**
 4. Licensed fabricators of Promat UK Ltd
 5. The Sterling Centre, Eastern Road, Bracknell, Berkshire RG12 2TD
Tel: 01344 381 400 Fax: 01344 381 401
e-mail: technical@promat.co.uk Web: www.promat.co.uk
6. **Scope of use**
 7. Smoke Extract Ductwork
8. **System types & cross section available**
 9. Non-insulated ducts, up to 0.2m² rectangular cross section, with no side greater than 0.75m
10. **Ductwork orientation**
 11. Horizontal
 12. Vertical
13. **Duct wall / Insulation thickness range**
 14. 1.2mm SR galvanized steel (insulation N/A)
15. **Nominal board density**
 16. N/A
17. **Maximum fire resistance to BS 476: Part 24**
 18. Up to 120min Stability and Integrity only
19. **Fire Assessment Report Number**
 20. LPC witnessed test, CDL 656
21. **Third party accreditation**
 22. N/A
23. **Quality assurance approvals**
 24. N/A
25. **Product appearance**
 26. Galvanized steel finish
27. **Other applications**
 28. Extract ducts within fire protected shafts, where the shaft provides the fire compartmentation.
 - 29.
 - 30.
 - 31.

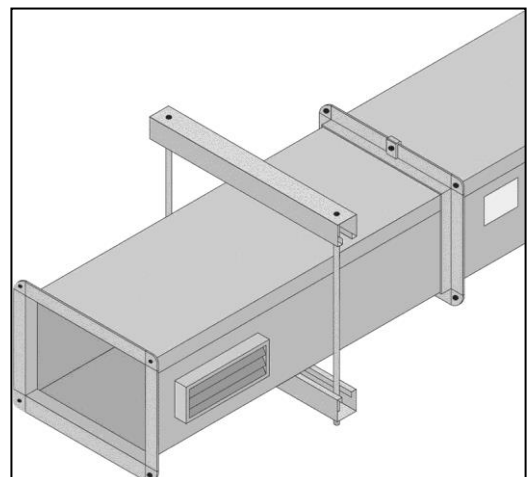

TABLE 1

System Name:

Promat DURADUCT® SR Ductwork System

Supply company name:

Licensed fabricators of Promat UK Ltd

Fire resisting duct - scope of use / type:

SMOKE EXTRACT DUCTS

Fire Assessment Report number:

LPC witnessed test CDL 656 dated: 2nd August 1999

Confirm that Ductwork system was tested & evaluated to BS 476 Part 24 [ISO 6944:1985]: Yes

ORIENTATION: Data for Horizontal Duct Applications												
DUCT SHAPE: Data for Rectangular Ducts												
Fire resistance stability integrity insulation	Maximum Duct Size (width) note 1	Thickness of duct	State if any panel stiffening is required	Max duct section length	State type of cross joints, section type & size	Max Spacing of duct stiffeners	Section type & size of duct stiffeners	Are stiffeners or tie rods needed?	Maximum spacing of hangers and bearers note 3	Thickness of fire protection layer	Fire protection material type & product name	Fixing method for fire protection layers
(minutes)	(m)	(mm)	(yes/no)	(m)	(mm)	(m)	(mm)	(yes/no)	(m)	(mm)		
120 / 120 / -	0.75	1.2	no	1.5	note 2	-	-	no	1.5	-	not required	-

DURADUCT® SR is a factory assembled modular duct system, fabricated in 1.2mm galvanised steel and designed for use with Promat DURADUCT® SMT and DURADUCT® LT ductwork systems, to provide runout feeder ductwork within a fire compartment. Penetrations through compartment walls are not therefore encountered.

Note 1 - maximum cross section area 0.2m²

Note 2 - Duct sections are constructed using Pittsburg lock seams or RSA, with 40mm rivited or spot welded flanges.

Note 3 - The duct hangers consist of 12mm threaded steel drop rods and P1000T Unistrut channel bearers.

32.

PROMATECT®-L500 (Encasement to existing steel ducts)

1. **Type of ductwork system**
 2. PROMATECT®-L500 is a non-combustible, low-density calcium silicate board, for fire encasement of DW/144 sheet metal ducts.
3. **Manufacturer / Supplier to the market / Preferred supplier**
 4. Approved fire protection contractors of Promat UK Ltd
 5. The Sterling Centre, Eastern Road, Bracknell, Berkshire RG12 2TD
Tel: 01344 381 400 Fax: 01344 381 401
e-mail: technical@promat.co.uk Web: www.promat.co.uk
6. **Scope of use**
 7. Ventilation Ductwork
 8. Smoke Extract Ductwork
9. **System types & cross section available**
 10. Fire insulation encasement to steel ducts. Rectangular duct only.
11. **Ductwork orientation**
 12. Horizontal
 13. Vertical
14. **Duct wall – Insulation thickness range**
 15. PROMATECT®-L500 20mm - 50mm / Rock wool insulation 50mm - 75mm
16. **Nominal board density**
 17. 500kg/m³
18. **Maximum fire resistance to BS 476: Part 24**
 19. up to 240min Stability, Integrity and Insulation
20. **Fire Assessment Report Number**
 21. WF No. 146968C
22. **Third party accreditation**
 23. Certifire Certificate of Approval No CF 423
24. **Quality assurance approvals**
 25. Production surveillance under BS EN ISO 9001:2000
26. **Product appearance**
 27. Off white colour with smooth sanded surface
28. **Other applications**
 29. Self supporting ducts
 30. Cable protection
 31. Mechanical and electrical services enclosure
 32. Access panels

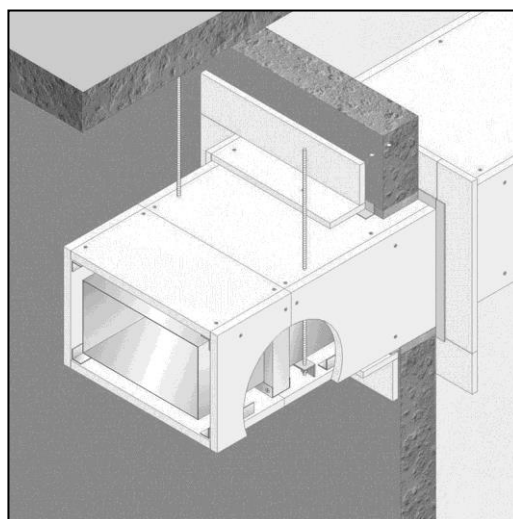

TABLE 1

System Name: **PROMATECT®-L500 (Encasement of Existing Steel Ducts)**
 Supply company name: **Promat UK Ltd**
 Fire resisting duct - scope of use / type: **VENTILATION & SMOKE EXTRACT DUCTS (ENCASEMENT OF STEEL DUCTS)**
 Fire Assessment Report number: **WF No. 146968C** dated: October 2006
 Confirm that Ductwork system was tested & evaluated to BS 476 Part 24 [ISO 6944:1985]: yes

ORIENTATION: Data for Horizontal Duct Applications												
DUCT SHAPE: Data for Rectangular Ducts												
Fire resistance stability integrity insulation	Maximum Duct Size (width x height)	Thickness of duct (PROMATECT®-L500)	State if any panel stiffening is required	Max duct section length (PROMATECT®-L500)	State type of cross joints, section type & size	Max Spacing of duct stiffeners	Section type & size of duct stiffeners	Are stiffeners or tie rods needed ?	Maximum spacing of hangers and bearers	Thickness of additional fire protection layer	Additional Fire protection material type & product name	Fixing method for fire protection layers
(minutes)	(m x m)	(mm)	(yes/no)	(m)	(mm)	(mm)	(mm)	(yes/no)	(m)	(mm)		
120 / 120 / 120	1.5 x 1.5	20mm	note 1	2.5	note 1	610	note 2	yes	2.4	50	Rock wool 100kg/m ³	note 3
120 / 120 / 120	3.0 x 1.5	20mm	note 1	1.2	note 1	610	note 2	yes	2.4	50	Rock wool 100kg/m ³	note 3

Note 1 - The steel duct must be constructed in accordance with the requirements of DW/144 - Specification for sheet metal duct work - low medium and high pressure/velocity air systems (published by the HVCA) - or equivalent specification. The ducts are constructed with rolled steel angle flange cross joints and the longitudinal seams are formed using Pittsburgh lock seam or the grooved corner seam. This specification gives details and minimum sizes of the steel sheet, stiffeners and sizes of angle sections to be used at various duct sizes.

Note 2 - At least 50mm x 50mm x 0.9mm steel channel collars (or deeper, if required to accommodate larger duct stiffeners, cross joints or thicker rock wool) are fitted around the duct at maximum 610mm centres. The channel are folded and fastened at the corners with minimum M4 steel rivets or self-tapping screws. The channels are filled with 100kg/m³ nominal density rock wool (if required). These channels are not fastened directly to the steel duct, where the soffit channels must be fastened to the stiffener angles or flanges of the steel duct.

Note 3 - Rock wool insulation is installed between the steel channels (full depth) according to the table above, and the PROMATECT®-L500 boards are fastened to the collars around the duct (coincident with transverse board joints) - and along 30mm x 30mm x 0.6mm longitudinal corner angles using M4 self-tapping screw at 200mm centres. Alternatively board corners may be fastened board to board using M4 screws of length twice the board thickness at 200mm centres. The transverse joints are covered with 9mm x 100mm SUPALUX® cover strips. Any longitudinal board joint, other than at duct corners, must be backed by a steel channel, and covered with 9mm SUPALUX® cover strips.

The steel duct is supported by steel hangers, consisting of a pair of threaded rods and angle rail under the steel duct, at maximum 2.4m centres. The rods and angles must be sized to ensure that the permitted stresses in Section 6 of this guidance document are not exceeded. Where hanger rods exceed 1.5m in length, they must be protected using the same thickness of PROMATECT®-L500 as is used for the duct cladding.

L-shaped collars in 80mm wide PROMATECT® -L500, of at least 20mm thickness, are installed around the duct to both faces of the wall penetration. Any space between the duct wall and the reveal to be filled with rock wool of minimum density 100kg/m³, together with 30mm layer of the same rock wool between the wall face and the collar. A duct joint or steel angle stiffener must be located within 100mm of the wall.

Inspection hatches up to 600mm x 600mm may be incorporated into the side of a PROMATECT® -L500 duct

TABLE 2

System Name: **PROMATECT®-L500 (Encasement of Existing Steel Ducts)**
 Supply company name: **Promat UK Ltd**
 Fire resisting duct - scope of use / type: **VENTILATION & SMOKE EXTRACT DUCTS (ENCASEMENT OF STEEL DUCTS)**
 Fire Assessment Report number: **WF No. 146968C dated: October 2006**
 Confirm that Ductwork system was tested & evaluated to BS 476 Part 24 [ISO 6944:1985]: **Yes**

ORIENTATION: Data for Horizontal Duct Applications												
DUCT SHAPE: Data for Rectangular Ducts												
Fire resistance stability integrity insulation	Maximum Duct Size (width x height)	Thickness of duct (PROMATECT®-L500)	State if any panel stiffening is required	Max duct section length (PROMATECT®-L500)	State type of cross joints, section type & size	Max Spacing of duct stiffeners	Section type & size of duct stiffeners	Are stiffeners or tie rods needed ?	Maximum spacing of hangers and bearers	Thickness of additional fire protection layer	Additional Fire protection material type & product name	Fixing method for fire protection layers
(minutes)	(m x m)	(mm)	(yes/no)	(m)	(mm)	(mm)	(mm)	(yes/no)	(m)	(mm)		
240 / 240 / 240	1.0 x 1.0	50mm	note 1	2.5	note 1	610	note 2	yes	2.4	75	Rock wool 100kg/m ³	note 3
240 / 240 / 240	3.0 x 1.5	50mm	note 1	1.2	note 1	610	note 2	yes	2.4	75	Rock wool 100kg/m ³	note 3

Note 1 - The steel duct must be constructed in accordance with the requirements of DW/144 - Specification for sheet metal duct work - low medium and high pressure/velocity air systems (published by the HVCA) - or equivalent specification. The ducts are constructed with rolled steel angle flange cross joints and the longitudinal seams are formed using Pittsburgh lock seam or the grooved corner seam. This specification gives details and minimum sizes of the steel sheet, stiffeners and sizes of angle sections to be used at various duct sizes.

Note 2 - At least 50mm x 50mm x 0.9mm steel channel collars (or deeper, if required to accommodate larger duct stiffeners, cross joints or thicker rock wool) are fitted around the duct at maximum 610mm centres. The channel are folded and fastened at the corners with minimum M4 steel rivets or self-tapping screws. The channels are filled with 100kg/m³ nominal density rock wool (if required). These channels are not fastened directly to the steel duct except for the 240min ducts greater than 1m wide, where the soffit channels must be fastened to the stiffener angles or flanges of the steel duct.

Note 3 - Rock wool insulation is installed between the steel channels (full depth) according to the table above, and the PROMATECT®-L500 boards are fastened to the collars around the duct (coincident with transverse board joints) - and along 30mm x 30mm x 0.6mm longitudinal corner angles using M4 self-tapping screw at 200mm centres. Alternatively board corners may be fastened board to board using M4 screws of length twice the board thickness at 200mm centres. The transverse joints are covered with 9mm x 100mm SUPALUX® cover strips. Any longitudinal board joint, other than at duct corners, must be backed by a steel channel, and covered with 9mm SUPALUX® cover strips.

The steel duct is supported by steel hangers, consisting of a pair of threaded rods and angle rail under the steel duct, at maximum 2.4m centres. The rods and angles must be sized to ensure that the permitted stresses in Section 6 of this guidance document are not exceeded. Where hanger rods exceed 1.5m in length, they must be protected using the same thickness of PROMATECT®-L500 as is used for the duct cladding.

L-shaped collars in 80mm wide PROMATECT® -L500, of at least 20mm thickness, are installed around the duct to both faces of the wall penetration. Any space between the duct wall and the reveal to be filled with rock wool of minimum density 100kg/m³, together with 30mm layer of the same rock wool between the wall face and the collar. A duct joint or steel angle stiffener must be located within 100mm of the wall.

Inspection hatches up to 600mm x 600mm may be incorporated into the side of a PROMATECT® -L500 duct

TABLE 3

System Name: **PROMATECT®-L500 (Encasement of Existing Steel Ducts)**
 Supply company name: **Promat UK Ltd**
 Fire resisting duct - scope of use / type: **VENTILATION & SMOKE EXTRACT DUCTS (ENCASEMENT OF STEEL DUCTS)**
 Fire Assessment Report number: **WF No. 146968C** dated: **October 2006**
 Confirm that Ductwork system was tested & evaluated to BS 476 Part 24 [ISO 6944:1985]: **Yes**

ORIENTATION: Data for Vertical Duct Applications												
DUCT SHAPE: Data for Rectangular Ducts												
Fire resistance stability integrity insulation	Max Duct Size (width x height)	Thickness of duct (PROMATECT® -L500)	State if any panel stiffening is required	Max duct section length (PROMATECT® -L500)	State type of cross joints, section type & size	Max Spacing of duct stiffeners	Section type & size of duct stiffeners	Are stiffeners or tie rods needed ?	Maximum spacing of hangers and bearers	Thickness of fire protection layer	Fire protection material type & product name	Fixing method for fire protection layers
(minutes)	(m x m)	(mm)	(yes/no)	(m)	(mm)	(mm)	(mm)	(yes/no)	(m)	(mm)		
120 / 120 / 120	1.5x 1.5	20mm	note 1	2.5	note 1	610	note 2	yes	n/a	50	Rock wool 100kg/m ³	note 3
240 / 240 / 240	1.0 x 1.0	50mm	note 1	1.2	note 1	610	note 2	yes	n/a	75	Rock wool 100kg/m ³	note 3

Note 1 - The steel duct must be constructed in accordance with the requirements of DW/144 - Specification for sheet metal duct work - low medium and high pressure/velocity air systems (published by the HVCA) - or equivalent specification. The ducts are constructed with rolled steel angle flange cross joints and the longitudinal seams are formed using Pittsburgh lock seam or the grooved corner seam. This specification gives details and minimum sizes of the steel sheet, stiffeners and sizes of angle sections to be used at various duct sizes.

Note 2 - At least 50mm x 50mm x 0.9mm steel channel collars (or deeper, if required to accommodate larger duct stiffeners, cross joints or thicker rock wool) are fitted around the duct at maximum 610mm centres. The channel are folded and fastened at the corners with minimum M4 steel rivets or self-tapping screws. The channels are filled with 100kg/m³ nominal density rock wool (if required). These channels are not fastened directly to the steel duct, where the soffit channels must be fastened to the stiffener angles or flanges of the steel duct.

Note 3 - Rock wool insulation is installed between the steel channels (full depth) according to the table above, and the PROMATECT®-L500 boards are fastened to the collars around the duct (coincident with transverse board joints) - and along 30mm x 30mm x 0.6mm longitudinal corner angles using M4 self-tapping screw at 200mm centres. Alternatively board corners may be fastened board to board using M4 screws of length twice the board thickness at 200mm centres. The transverse joints are covered with 9mm x 100mm SUPALUX® cover strips. Any longitudinal board joint, other than at duct corners, must be backed by a steel channel, and covered with 9mm SUPALUX® cover strips.

Where the duct passes through a compartment floor the penetration is sealed with PROMASEAL® Fire Compound to a thickness at least that required to provide fire resistance equal to that of the floor. A PROMATECT®-L500 L-shaped collar, made from 80mm x 20mm board strips, is fastened to the duct on the upper side of the floor using steel screws.

The weight of the duct assembly must be taken by the steel duct and not by the PROMATECT®-L500. Steel angles may be used to support the steel duct at the floor penetrations. Where a vertical duct is located adjacent to a wall, the duct may be restrained by the wall with steel threaded rods and support sections.

PROMATECT®-L500 (Self supporting ducts)

1. Type of ductwork system

33. PROMATECT® L500 is a non-combustible, low-density calcium silicate board, that is screwed (or stapled) and glued together to form the duct.

2. Manufacturer / Supplier to the market / Preferred supplier

34. Approved fire protection contractors of Promat UK Ltd
35. The Sterling Centre, Eastern Road, Bracknell, Berkshire RG12 2TD
Tel: 01344 381 400 Fax: 01344 381 401
e-mail: technical@promat.co.uk Web: www.promat.co.uk

3. Scope of use

36. Ventilation Ductwork
37. Smoke Extract Ductwork

4. System types & cross section available

38. Self supporting rectangular duct system.

5. Ductwork orientation

39. Horizontal
40. Vertical

6. Duct wall – Insulation thickness range

41. PROMATECT®-L500 25mm - 52mm

7. Nominal board density

42. 500kg/m³

8. Maximum fire resistance to BS 476: Part 24

43. up to 240min Stability, Integrity and Insulation

9. Fire Assessment Report Number

44. WF No. 146968D

10. Third party accreditation

45. Certifire Certificate of Approval No CF 423

11. Quality assurance approvals

46. Production surveillance under BS EN ISO 9001:2000

12. Product appearance

47. Off white colour with smooth sanded surface

13. Other applications

48. Encasement of steel ducts
49. Cable protection
50. Mechanical and electrical services enclosure
51. Access panels

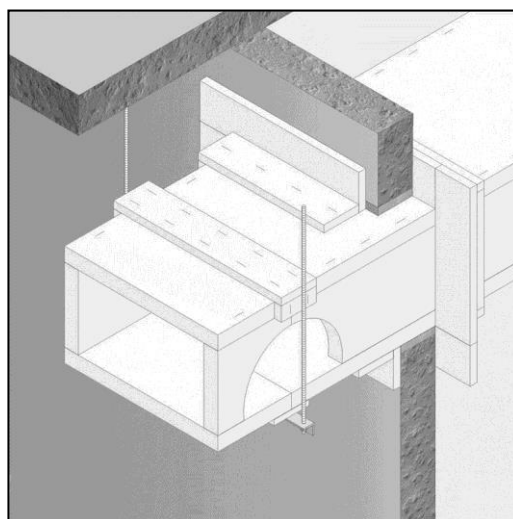

TABLE 1

System Name: **PROMATECT®-L500 (Self-Supporting Ducts)**
 Supply company name: **Promat UK Ltd**
 Fire resisting duct - scope of use / type: **VENTILATION & SMOKE EXTRACT DUCTS (SELF-SUPPORTING DUCTS)**
 Fire Assessment Report number: **WF No. 146968D** dated: **October 2006**
 Confirm that Ductwork system was tested & evaluated to BS 476 Part 24 [ISO 6944:1985]: **Yes**

ORIENTATION: Data for Horizontal Duct Applications												
DUCT SHAPE: Data for Rectangular Ducts												
Fire resistance stability integrity insulation	Maximum Duct Size (width x height)	Thickness of duct (PROMATECT®-L500) note 1	State if any panel stiffening is required	Max duct section length	State type of cross joints, section type & size	Max Spacing of duct stiffeners	Section type & size of duct stiffeners	Are stiffeners or tie rods needed ?	Maximum spacing of hangers and bearers	Thickness of fire protection layer	Fire protection material type & product name	Fixing method for fire protection layers
(minutes)	(m x m)	(mm)	(yes/no)	(m)	(mm)	(m)	(mm)	(yes/no)	(m)	(mm)		
60 / 60 / 60	1.2 x 1.2	35mm	n/a	2.5	note 2	-	-	no	1.25	Provided by the board	PROMATECT®-L500	note 4
60 / 60 / 60	2.0 x 1.25	35mm	n/a	1.2	note 2	1 row	note 3	yes	1.25	Provided by the board	PROMATECT®-L500	note 4
60 / 60 / 60	3.0 x 1.25	35mm	n/a	1.2	note 2	2 rows	note 3	yes	1.25	Provided by the board	PROMATECT®-L500	note 4

Note 1 - The PROMATECT®-L500 panels form the integral self-supporting fire resistant duct, without the need for a steel lining. Maximum duct pressure +/- 500Pa. Duct pressure may be increased to +/- 750Pa if the PROMATECT®-L500 duct wall thickness is increased to 40mm.

Note 2 - Joints between duct modules are formed using 100mm wide x 9mm thick SUPALUX® strips, screwed and bonded using VICUBOND® WR.

Note 3 - Ducts are stiffened using one or two rows of 250mm wide x 40mm thick PROMATECT®-L500 soldiers, at maximum 600mm centres down the length of the duct.

Note 4 - PROMATECT®-L500 self-supporting ducts are normally prefabricated off-site and are constructed using board to board corner construction with a glue and screw (or staple) method, to form boxed sections.

The hangers consist of threaded steel drop rods and steel angle or channels bearers. The rods and angles must be sized to ensure that the permitted stresses in Section 6 of this guidance document are not exceeded. Where hanger rods exceed 1.5m in length, they must be protected using the same thickness of PROMATECT®-L500. Other conditions may apply.

L-shaped collars in 80mm wide PROMATECT®-L500, of at least 20mm thickness, are installed around the duct to both faces of the wall penetration. Any space between the duct wall and the reveal to be filled with rock wool of minimum density 100kg/m³, together with 30mm layer of the same rock wool between the wall face and the collar.

Inspection hatches up to 600mm x 600mm may be incorporated into the side of a PROMATECT®-L500 duct.

TABLE 2

System Name:

PROMATECT®-L500 (Self-Supporting Ducts)

Supply company name:

Promat UK Ltd

Fire resisting duct - scope of use / type:

VENTILATION & SMOKE EXTRACT DUCTS (SELF-SUPPORTING DUCTS)

Fire Assessment Report number:

WF No. 146968D dated: October 2006

Confirm that Ductwork system was tested & evaluated to BS 476 Part 24 [ISO 6944:1985]: Yes

ORIENTATION: Data for Horizontal Duct Applications												
DUCT SHAPE: Data for Rectangular Ducts												
Fire resistance stability integrity insulation	Maximum Duct Size (width x height)	Thickness of duct (PROMATECT®-L500) note 1	State if any panel stiffening is required	Max duct section length	State type of cross joints, section type & size	Max Spacing of duct stiffeners note 3	Section type & size of duct stiffeners	Are stiffeners or tie rods needed ?	Maximum spacing of hangers and bearers	Thickness of fire protection layer	Fire protection material type & product name	Fixing method for fire protection layers
(minutes)	(m x m)	(mm)	(yes/no)	(m)	(mm)	(m)	(mm)	(yes/no)	(m)	(mm)		
90 / 90 / 90	1.2 x 1.2	40mm	n/a	2.5	note 2	-	-	no	1.25	Provided by the board	PROMATECT®-L500	note 4
90 / 90 / 90	2.0 x 1.25	40mm	n/a	1.2	note 2	1 row	note 3	yes	1.25	Provided by the board	PROMATECT®-L500	note 4
90 / 90 / 90	3.0 x 1.25	40mm	n/a	1.2	note 2	2 rows	note 3	yes	1.25	Provided by the board	PROMATECT®-L500	note 4

Note 1 - The PROMATECT®-L500 panels form the integral self-supporting fire resistant duct, without the need for a steel lining. Maximum duct pressure +/- 750Pa.

Note 2 - Joints between duct modules are formed using 100mm wide x 9mm thick SUPALUX® strips, bonded and screwed using VICUBOND® WR.

Note 3 - Ducts are stiffened using one or two rows of 250mm wide x 40mm thick PROMATECT®-L500 soldiers, at maximum 600mm centres down the length of the duct.

Note 4 - PROMATECT®-L500 self-supporting ducts are normally prefabricated off-site and are constructed using board to board corner construction with a glue and screw (or staple) method, to form boxed sections.

The hangers consist of threaded steel drop rods and steel angle or channels bearers. The rods and angles must be sized to ensure that the permitted stresses in Section 6 of this guidance document are not exceeded. Where hanger rods exceed 1.5m in length, they must be protected using the same thickness of PROMATECT®-L500. Other conditions may apply.

L-shaped collars in 80mm wide PROMATECT®-L500, of at least 20mm thickness, are installed around the duct to both faces of the wall penetration. Any space between the duct wall and the reveal to be filled with rock wool of minimum density 100kg/m³, together with 30mm layer of the same rock wool between the wall face and the collar.

Inspection hatches up to 600mm x 600mm may be incorporated into the side of a PROMATECT®-L500 duct

TABLE 3

System Name: **PROMATECT®-L500 (Self-Supporting Ducts)**
 Supply company name: **Promat UK Ltd**
 Fire resisting duct - scope of use / type: **VENTILATION & SMOKE EXTRACT DUCTS (SELF-SUPPORTING DUCTS)**
 Fire Assessment Report number: **WF No. 146968D** dated: **October 2006**
 Confirm that Ductwork system was tested & evaluated to BS 476 Part 24 [ISO 6944:1985]: **Yes**

ORIENTATION: Data for Horizontal Duct Applications												
DUCT SHAPE: Data for Rectangular Ducts												
Fire resistance stability integrity insulation	Maximum Duct Size (width x height)	Thickness of duct (PROMATECT® -L500) note 1	State if any panel stiffening is required	Max duct section length	State type of cross joints, section type & size	Max Spacing of duct stiffeners note 3	Section type & size of duct stiffeners	Are stiffeners or tie rods needed ?	Maximum spacing of hangers and bearers	Thickness of fire protection layer	Fire protection material type & product name	Fixing method for fire protection layers
(minutes)	(m x m)	(mm)	(yes/no)	(m)	(mm)	(m)	(mm)	(yes/no)	(m)	(mm)		
120 / 120 / 120	1.2 x 1.2	52mm	n/a	2.5	note 2	-	-	no	1.25	Provided by the board	PROMATECT® -L500	note 4
120 / 120 / 120	2.0 x 1.25	52mm	n/a	1.2	note 2	1 row	note 3	yes	1.25	Provided by the board	PROMATECT® -L500	note 4
120 / 120 / 120	3.0 x 1.25	52mm	n/a	1.2	note 2	2 rows	note 3	yes	1.25	Provided by the board	PROMATECT® -L500	note 4

Note 1 - The PROMATECT® -L500 panels form the integral self-supporting fire resistant duct, without the need for a steel lining. Maximum duct pressure +/- 750Pa

Note 2 - Joints between duct modules are formed using 100mm wide x 9mm thick SUPALUX® strips, bonded and screwed using VICUBOND® WR

Note 3 - Ducts are stiffened using one or two rows of 250mm wide x minimum 40mm thick PROMATECT® -L500 soldiers, at maximum 600mm centres down the length of the duct.

Note 4 - PROMATECT® -L500 self-supporting ducts are normally prefabricated off-site and are constructed using board to board corner construction with a glue and screw (or staple) method, to form boxed sections.

The hangers consist of threaded steel drop rods and steel angle or channels bearers. The rods and angles must be sized to ensure that the permitted stresses in Section 6 of this guidance document are not exceeded. Where hanger rods exceed 1.5m in length, they must be protected using the same thickness of PROMATECT® -L500. Other conditions may apply.

L-shaped collars in 80mm wide PROMATECT® -L500, of at least 20mm thickness, are installed around the duct to both faces of the wall penetration. Any space between the duct wall and the reveal to be filled with rock wool of minimum density 100kg/m³, together with 30mm layer of the same rock wool between the wall face and the collar.

Inspection hatches up to 600mm x 600mm may be incorporated into the side of a PROMATECT® -L500 duct

TABLE 4

System Name: **PROMATECT®-L500 (Self-Supporting Ducts)**
 Supply company name: **Promat UK Ltd**
 Fire resisting duct - scope of use / type: **VENTILATION & SMOKE EXTRACT DUCTS (SELF-SUPPORTING DUCTS)**
 Fire Assessment Report number: **WF No. 146968D** dated: October 2006
 Confirm that Ductwork system was tested & evaluated to BS 476 Part 24 [ISO 6944:1985]: **Yes**

ORIENTATION: Data for Vertical Duct Applications												
DUCT SHAPE: Data for Rectangular Ducts												
Fire resistance stability integrity insulation	Maximum Duct Size (width x height)	Thickness of duct (PROMATECT®-L500) note 1	State if any panel stiffening is required	Max duct section length	State type of cross joints, section type & size	Max Spacing of duct stiffeners	Section type & size of duct stiffeners	Are stiffeners or tie rods needed ?	Maximum spacing of hangers and bearers	Thickness of fire protection layer	Fire protection material type & product name	Fixing method for fire protection layers
(minutes)	(m x m)	(mm)	(yes/no)	(m)	(mm)	(m)	(mm)	(yes/no)	(m)	(mm)		
60 / 60 / 60	1.2 x 1.2	35mm	n/a	2.5	note 2	-	-	no	n/a	Provided by the board	PROMATECT®-L500	note 3
90 / 90 / 90	1.2 x 1.2	40mm	n/a	2.5	note 2	-	-	no	n/a	Provided by the board	PROMATECT®-L500	note 3
120 / 120 / 120	1.2 x 1.2	52mm	n/a	2.5	note 2	-	-	no	n/a	Provided by the board	PROMATECT®-L500	note 3

Note 1 - The PROMATECT®-L500 panels form the integral self-supporting fire resistant duct, without the need for a steel lining. Maximum duct pressure +/- 500Pa. (Duct pressure +/- 750Pa for PROMATECT®-L500 duct wall thickness of 40mm or above.)

Note 2 - Joints between duct modules are formed using 100mm wide x 9mm thick SUPALUX® strips, bonded and screwed using VICUBOND® WR.

Note 3 - PROMATECT®-L500 self-supporting ducts are normally prefabricated off-site and are constructed using board to board corner construction with a glue and screw (or staple) method, to form boxed sections.

Where the duct passes through a compartment floor the penetration is sealed with PROMASEAL® Fire Compound of at least the thickness required to provide fire resistance equal to that of the floor. A PROMATECT®-L500 L-shaped collar, made from 80mm x 20mm board strips, is fastened to the duct on the upper side of the floor using VICUBOND® WR adhesive and steel screws or staples. The collar supports the weight of the duct above the floor.

Where a vertical duct is located adjacent to a wall, the duct may be restrained by the wall with steel threaded rods and support sections.

Inspection hatches up to 600mm x 600mm may be incorporated into the side of a PROMATECT®-L500 duct

Promat VICUCLAD® (Encasement of existing steel ducts)

1. **Type of ductwork system**
 2. VICUCLAD® is a non-combustible lightweight vermiculite board, for the encasement of DW/144 sheet metal ducts.
3. **Manufacturer / Supplier to the market / Preferred supplier**
 4. Approved fire protection contractors of Promat UK Ltd
 5. The Sterling Centre, Eastern Road, Bracknell, Berkshire RG12 2TD
Tel: 01344 381 400 Fax: 01344 381 401
e-mail: technical@promat.co.uk Web: www.promat.co.uk
6. **Scope of use**
 7. Ventilation Ductwork
Smoke Extract Ductwork
Kitchen Extract Ductwork
8. **System types & cross section available**
 9. Fire insulation encasement to steel ducts. Rectangular ducts only
10. **Ductwork orientation**
 11. Horizontal
Vertical
12. **Duct wall – Insulation thickness range**
 13. VICUCLAD® 25mm – 70mm
14. **Nominal board density**
 15. 405kg/m³
16. **Maximum fire resistance to BS 476: Part 24**
 17. up to 240min Stability, Integrity and Insulation
18. **Fire Assessment Report Number**
 19. WF No. 153828
20. **Third party accreditation**
 21. Certifire Certificate of Approval No CF 419
22. **Quality assurance approvals**
 23. Production surveillance under BS EN ISO 9001:2000
24. **Product appearance**
 25. Oatmeal coloured vermiculite board
26. **Other applications**
 27. Gas pipe protection
Thermal insulation
 - 28.

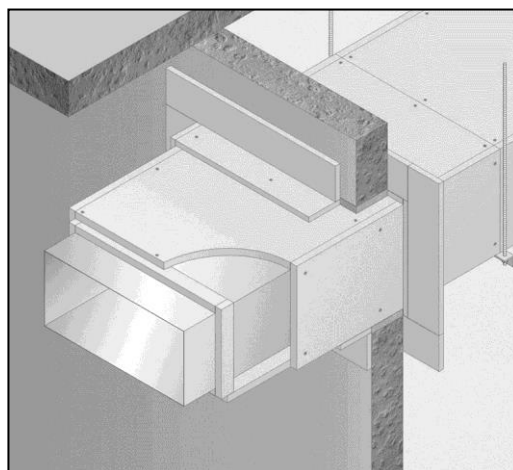

TABLE 1

System Name: **Promat VICUCLAD® (Encasement of Existing Steel Ducts)**
 Supply company name: **Promat UK Ltd**
 Fire resisting duct - scope of use / type: **VENTILATION & SMOKE EXTRACT DUCTS (ENCASEMENT OF STEEL DUCTS)**
 Fire Assessment Report number: **WF No. 153828 dated: October 2006**
 Confirm that Ductwork system was tested & evaluated to BS 476 Part 24 [ISO 6944:1985]: **yes**

ORIENTATION: Data for Horizontal & Vertical Duct Applications (Integrity Only)												
DUCT SHAPE: Data for Rectangular Ducts												
Fire resistance stability integrity insulation	Maximum Duct Size (width) note 1	Thickness of duct (VICUCLAD®)	State if any panel stiffening is required	Max duct section length (VICUCLAD®)	State type of cross joints, section type & size	Max Spacing of duct stiffeners	Section type & size of duct stiffeners	Are stiffeners or tie rods needed ?	Maximum spacing of hangers and bearers	Thickness of additional fire protection layer	Additional Fire protection material type & product name	Fixing method for fire protection layers
(minutes)	(m)	(mm)	(yes/no)	(m)	(mm)	(mm)	(mm)	(yes/no)	(m)	(mm)		
60 / 60 / -	2.0	30	note 2	1.0	note 2	610	note 3	yes	1.22	not required	-	note 3
120 / 120 / -	2.0	35	note 2	1.0	note 2	610	note 3	yes	1.22	not required	-	note 3
240 / 240 / -	1.75	45	note 2	1.0	note 2	610	note 3	yes	1.22	not required	-	note 3

Note 1 – Maximum duct depth 900mm

Note 2 - The steel duct must be constructed in accordance with the requirements of DW/144 – Specification for sheet metal duct work – low medium and high pressure/velocity air systems (published by the HVCA) - or equivalent specification. The ducts are constructed with rolled steel angle-flange cross joints and the longitudinal seams are formed using Pittsburgh lock seam or the grooved corner seam. This specification gives details and minimum sizes of the steel sheet, stiffeners and sizes of angle sections to be used at various duct sizes.

Note 3 – VICUCLAD® battens are fitted around the duct at maximum 610mm centres. (of the same thickness as the outer casing, or increased to accommodate larger stiffener or cross joints if necessary). and VICUCLAD® boards are fitted around the duct. Boards are bonded to the battens and along the longitudinal corners using VICUBOND® WR adhesive, and wire nails at 300mm centres. Where the duct requires more than a VICUCLAD® board length to span the duct width, the VICUCLAD® batten and VICUCLAD® boards to the underside of the duct are fastened to the steel duct using M4 screws at maximum 500mm centres. Any longitudinal board joint, other than at duct corners, must be backed by VICUCLAD® battens.

The ducts assembly is supported by steel hangers, consisting of a pair of threaded rods and angle rail under the clad duct, at maximum 1220mm centres (coincident with the support battens). The rods and angles must be sized to ensure that the permitted stresses in Section 6 of this guidance document are not exceeded. Where hanger rods exceed 2m in length, they must be protected using the same thickness of VICUCLAD® (or VICUTUBE®) as is used for the duct cladding.

L-shaped collars in 100mm wide Vicuclad in the same thickness board as the duct cladding must be installed around the duct to both faces of the wall or floor, and bonded to the duct using VICUBOND® WR.

TABLE 2

System Name:

Promat VICUCLAD® (Encasement of Existing Steel Ducts)

Supply company name:

Promat UK Ltd

Fire resisting duct - scope of use / type:

VENTILATION & SMOKE EXTRACT DUCTS (ENCASEMENT OF STEEL DUCTS)

Fire Assessment Report number:

WF No. 153828 dated: October 2006

Confirm that Ductwork system was tested & evaluated to BS 476 Part 24 [ISO 6944:1985]: yes

ORIENTATION: Data for Horizontal & Vertical Duct Applications												
DUCT SHAPE: Data for Rectangular Ducts												
Fire resistance stability integrity insulation	Maximum Duct Size (width) note 1	Thickness of duct (VICUCLAD®)	State if any panel stiffening is required	Max duct section length (VICUCLAD®)	State type of cross joints, section type & size	Max Spacing of duct stiffeners	Section type & size of duct stiffeners	Are stiffeners or tie rods needed ?	Maximum spacing of hangers and bearers	Thickness of additional fire protection layer	Fire protection material type & product name	Fixing method for fire protection layers
(minutes)	(m)	(mm)	(yes/no)	(m)	(mm)	(mm)	(mm)	(yes/no)	(m)	(mm)		
60 / 60 / 60	2.0	30	note 2	1.0	note 2	610	note 3	yes	1.22	30	- Rock wool 60kg/m ³	note 3
120 / 120 / 120	2.0	40	note 2	1.0	note 2	610	note 3	yes	1.22	40	Rock wool 800kg/m ³	note 3
240 / 240 / 240	1.5	70	note 2	1.0	note 2	610	note 3	yes	1.22	70	Rock wool 80kg/m ³	note 3

Note 1 – Maximum duct depth 900mm

Note 2 - The steel duct must be constructed in accordance with the requirements of DW/144 – Specification for sheet metal duct work – low medium and high pressure/velocity air systems (published by the HVCA) - or equivalent specification. The ducts are constructed with rolled steel angle-flange cross joints and the longitudinal seams are formed using Pittsburgh lock seam or the grooved corner seam. This specification gives details and minimum sizes of the steel sheet, stiffeners and sizes of angle sections to be used at various duct sizes.

Note 3 - VICUCLAD® battens are fitted around the duct at maximum 610mm centres. (of the same thickness as the outer casing, or increased to accommodate larger stiffener or cross joints if necessary). Rock wool insulation is installed between the battens and VICUCLAD® boards are fitted around the duct. Boards are bonded to the battens and along the longitudinal corners using VICUBOND® WR adhesive, and wire nails at 300mm centres. Where the duct requires more than a VICUCLAD® board length to span the duct width, the VICUCLAD® batten and VICUCLAD® boards to the underside of the duct are fastened to the steel duct using M4 screws at maximum 500mm centres. Any longitudinal board joint, other than at duct corners, must be backed by VICUCLAD® battens.

The ducts assembly is supported by steel hangers, consisting of a pair of threaded rods and angle rail under the clad duct, at maximum 1220mm centres (coincident with the support battens). The rods and angles must be sized to ensure that the permitted stresses in Section 6 of this guidance document are not exceeded. Where hanger rods exceed 2m in length, they must be protected using the same thickness of VICUCLAD® (or VICUTUBE®) as is used for the duct cladding.

L-shaped collars in 100mm wide Vicuclad in the same thickness board as the duct cladding must be installed around the duct to both faces of the wall or floor, and bonded to the duct using VICUBOND® WR.

TABLE 3

System Name: **Promat VICUCLAD® (Encasement of Existing Steel Ducts)**
 Supply company name: **Promat UK Ltd**
 Fire resisting duct - scope of use / type: **KITCHEN EXTRACT DUCTS (ENCASEMENT OF STEEL DUCTS)**
 Fire Assessment Report number: **WF No. 153828 dated: October 2006**
 Confirm that Ductwork system was tested & evaluated to BS 476 Part 24 [ISO 6944:1985]: **Yes**

ORIENTATION: Data for Horizontal & Vertical Duct Applications												
DUCT SHAPE: Data for Rectangular Ducts												
Fire resistance stability integrity insulation note 1	Maximum Duct Size (width) note 1	Thickness of duct (VICUCLAD®)	State if any panel stiffening is required	Max duct section length (VICUCLAD®)	State type of cross joints, section type & size	Max Spacing of duct stiffeners	Section type & size of duct stiffeners	Are stiffeners or tie rods needed ?	Maximum spacing of hangers and bearers	Thickness of additional fire protection layer	Fire protection material type & product name	Fixing method for fire protection layers
(minutes)	(m)	(mm)	(yes/no)	(m)	(mm)	(mm)	(mm)	(yes/no)	(m)	(mm)		
30 / 30 / 30	2.0	50	note 2	1.0	note 2	610	note 3	yes	1.22	not required	-	note 3
60 / 60 / 60	2.0	50	note 2	1.0	note 2	610	note 3	yes	1.22	60	Rock wool 60kg/m ³	note 3
90 / 90 / 90	2.0	70	note 2	1.0	note 2	610	note 3	yes	1.22	70	Rock wool 80kg/m ³	note 3

Note 1 – Maximum duct depth 900mm

Note 2 - The steel duct must be constructed in accordance with the requirements of DW/144 – Specification for sheet metal duct work – low medium and high pressure/velocity air systems (published by the HVCA) - or equivalent specification. The ducts are constructed with rolled steel angle-flange cross joints and the longitudinal seams are formed using Pittsburgh lock seam or the grooved corner seam. This specification gives details and minimum sizes of the steel sheet, stiffeners and sizes of angle sections to be used at various duct sizes.

Note 3 - VICUCLAD® battens are fitted around the duct at maximum 610mm centres. (of the same thickness as the outer casing, or increased to accommodate larger stiffener or cross joints if necessary). Rock wool insulation is installed between the battens (if necessary) and VICUCLAD® boards are fitted around the duct. Boards are bonded to the battens and along the longitudinal corners using VICUBOND® WR adhesive, and wire nails at 300mm centres. Where the duct requires more than a VICUCLAD® board length to span the duct width, the VICUCLAD® batten and VICUCLAD® boards to the underside of the duct are fastened to the steel duct using M4 screws at maximum 500mm centres. Any longitudinal board joint, other than at duct corners, must be backed by VICUCLAD® battens.

The ducts assembly is supported by steel hangers, consisting of a pair of threaded rods and angle rail under the clad duct, at maximum 1220mm centres (coincident with the support battens). The rods and angles must be sized to ensure that the permitted stresses in Section 6 of this guidance document are not exceeded. Where hanger rods exceed 2m in length, they must be protected using the same thickness of VICUCLAD® (or VICUTUBE®) as is used for the duct cladding.

L-shaped collars in 100mm wide Vicuclad in the same thickness board as the duct cladding must be installed around the duct to both faces of the wall or floor, and bonded to the duct using VICUBOND® WR.

FIREPRO FIREDUCT SYSTEM (previously Conlit Ductwork System)

1. Type of ductwork system

2. Resin bonded rock wool board, pre-formed circular section and pipe section mat supplied faced on one side with reinforced aluminium foil. Installed onto existing steel ducts constructed to meet requirements of system certification.

3. Application technique - FIRE DUCT SLAB

4. **Welded pin fixing methods.** Attachment by welded pins allows extremely rapid installation with slab joints simply butted together. Welded pins are generally spaced at 350mm maximum centres along the length of the duct and at 500mm maximum centres across the width and depth of the duct. Pins are required on all four sides of vertical ducts, but may be omitted from the top face of horizontal ducts.

5. **Welded pin method 1.** Longitudinal corner joints fixed with pigtail screws at 250mm maximum centres (screw length to be 2x slab thickness). Side wall slabs must overlap top and bottom slabs. Cross-joints bonded with Firepro Glue.

6. **Welded pin method 2.** All joints bonded with Firepro Glue. Slabs may overlap in either direction.

7. **Welded pin method 3** Longitudinal corner joints fixed with pigtail screws at 250mm maximum centres (screw length to be 2x slab thickness). Side wall slabs must overlap top and bottom slabs. Cross-joints protected with centrally positioned 100mm wide Fire Duct cover strips. Strips fixed with pigtail screws at 250mm maximum centres along both long edges.

8. **Mitre-joint fixing method.** All joints bonded with Firepro Glue. Longitudinal corner joints secured with nails while Firepro Glue cures. The use of mitre-joints at slab corners allows installation in situations where pin welding may not be practicable. Nails are generally spaced at 500mm maximum centres.

9. Application technique - FIRE DUCT SECTION & FIRE DUCT PSM

10. All joints and grooves in Fire Duct Section/Fire Duct PSM are glued with Firepro Glue. Steel bands or wires are fitted circumferentially to the system at 300mm nominal centres to hold all joints and grooves tightly closed while the glue cures. Where required, cover strips and bearer protection pieces are cut from Fire Duct Section or Fire Duct PSM of the appropriate diameter. The foil covering is to be removed from the area of Fire Duct Section immediately beneath the cover strips prior to gluing into position and securing with steel nails or pins.

11. Manufacturer / supplier to the market / preferred supplier

12. Rockwool Limited, Pencoed, Bridgend, CF35 6NY

13. Telephone 01656 862621. www.rockwool.co.uk

14. Scope of use

15. [1] Ventilation ductwork

16. [2] Smoke extract ductwork

17. [3] Kitchen extract ductwork

18. System Types & Cross Section available

19. Addition of **fire protecting** layer to steel duct section [rectangular, circular, oval]

20. Ductwork orientation

21. [i] Horizontal ductwork

22. [ii] Vertical ductwork

23. Duct wall /insulation thickness range

24. Minimum thickness of underlying steel duct: 0.8mm

Available insulation thickness: 40mm and 90mm.

25. Maximum fire resistance to BS 476- Part 24

	Maximum duration (hrs)	
	Stability & Integrity	Insulation
Fire Duct (BS476-24 Type A + B)	2	2
Smoke Duct (BS476-24 Type A + B)	2	2
Kitchen Extract (BS476-24 Type A + B)	1	1

26. Fire Assessment Report Number

27. BRE report CC 80537, Review 5, Issue 2

28. Appearance

29. Bright reinforced aluminium foil faced, muted green-brown stone wool.

30. Third party accreditation / Quality assurance approvals

31. FirePro FireDuct products are manufactured by Rockwool, which operates systems that involve high levels of approval and assessment by third parties such as LPCB, BSI, BBA, LR and FM.

32. Quality Assurance management certified to ISO 9001.

33. Durability

34. Rockwool is water repellent, rot proof, chemically inert, does not support fungal or bacterial growth and does not offer sustenance to vermin

35. Other ductwork applications not addressed above

36. Thermal and acoustic insulation

37. Reaction to fire classification A1 as defined in BS EN 13501:1 (wall & ceiling linings).

38. Non-combustible and Class 0, as defined in Approved Document B of Building Regulations.

39.

TABLE 1

System name:

Supply company name:

Fire resisting duct - scope of use / type:

Fire assessment report number:

Confirm that Ductwork system was tested and evaluated to BS 476:Part 24 [ISO 6944]: Yes

FIREPRO FIREDUCT SYSTEM (previously Conlit Ductwork System)

Rockwool Limited. telephone 01656 862621, www.rockwool.co.uk

VENTILATING DUCTS AND SMOKE EXTRACT DUCTS (additional fire protecting layer to steel ducts)

BRE report CC 80537, Review 5 Issue 2

ORIENTATION: Data for horizontal and vertical duct applications												
DUCT SHAPE: Data for rectangular, circular and oval ducts												
Fire resistance (a) stability (b) integrity (c) insulation	Maximum duct size: Longer side or diameter	Thickness of ducts (a) steel (b) board (c) coating	State if any panel stiffening is required	Maximum duct section length	State type of cross joints, section type & size	Maximum spacing of duct stiffeners	Section type and size of duct stiffeners	Are stiffeners or tie rods needed?	Maximum spacing of hangers and bearers	Thickness of fire protective layer	Fire protection material type & product name	Fixing method for fire protective layers
(minutes)	(mm)	(mm)	(yes/no)	(m)	(mm)	(m)	(mm)	(yes/no)	(m)	(mm)		
Up to 60 (a, b & c)	Side: 4000 Dia.: 1525	(a) 0.8 (see note 2) (b) 40 (c) n/a	no	-	DW 144 (1998): J3, J4, J5 & J6 (see notes 3 and 4 below)	See DW 144, Sections 10.5.1, 10.5.2 and 16.5	See DW 144, figs 18-23 and table 11	May be needed at penetration	1.5	40	Rockwool FirePro FireDuct	Various - see facing data page
Up to 120 (a, b & c)	Side: 4000 Dia.: 1525	(a) 0.8 (see note 2) (b) 90 (c) n/a	no	-	DW 144 (1998): J3, J4, J5 & J6 (see notes 3 and 4 below)	See DW 144, Sections 10.5.1, 10.5.2 and 16.5	See DW 144, figs 18-23 and table 11	May be needed at penetration	1.5	90	Rockwool FirePro FireDuct	Various - see facing data page

NB: Notes provided below Table 2 are applicable to both tables

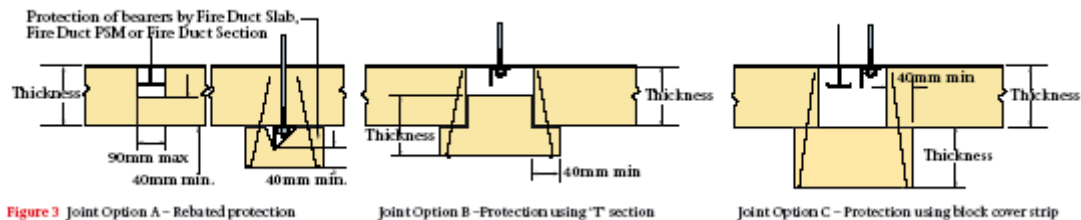

JOINT COVER OPTIONS

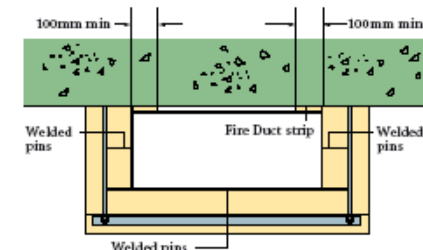
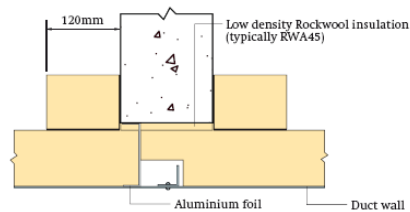
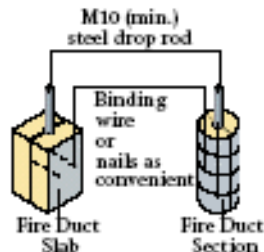

TABLE 2

System name:

FIREPRO FIREDUCT SYSTEM (previously Conlit Ductwork System)

Supply company name:

Rockwool Limited. telephone 01656 862621, www.rockwool.co.uk

Fire resisting duct - scope of use / type:

KITCHEN EXTRACT DUCTS (additional fire protecting layer to steel ducts)

Fire assessment report number:

BRE report CC 80537, Review 5 Issue 2

Confirm that Ductwork system was tested and evaluated to BS 476:Part 24 [ISO 6944]: Yes

ORIENTATION: Data for horizontal and vertical duct applications												
DUCT SHAPE: Data for rectangular, circular and oval ducts												
Fire resistance (a) stability (b) integrity (c) insulation	Maximum duct size: Longer side or diameter	Thickness of ducts (a) steel (b) board (c) coating	State if any panel stiffening is required	Maximum duct section length	State type of cross joints, section type & size	Maximum spacing of duct stiffeners	Section type and size of duct stiffeners	Are stiffeners or tie rods needed?	Maximum spacing of hangers and bearers	Thickness of fire protective layer	Fire protection material type & product name	Fixing method for fire protective layers
(mins)	(mm)	(mm)	(yes/no)	(m)	(mm)	(m)	(mm)	(yes/no)	(m)	(mm)		
Up to 30 (a, b & c)	Side: 4000 Dia.: 1525	(a) 0.8 (see note 2) (b) 40 (c) n/a	no	-	DW 144 (1998): J3, J4, J5 & J6 (see notes 3 and 4 below)	See DW 144, Sections 10.5.1, 10.5.2 and 16.5	See DW 144, figs 18-23 and table 11	May be needed at penetration	1.5	40	Rockwool FirePro FireDuct	Various - see facing data page
Up to 60 (a, b & c)	Side: 4000 Dia.: 1525	(a) 0.8 (see note 2) (b) 90 (c) n/a	no	-	DW 144 (1998): J3, J4, J5 & J6 (see notes 3 and 4 below)	See DW 144, Sections 10.5.1, 10.5.2 and 16.5	See DW 144, figs 18-23 and table 11	May be needed at penetration	1.5	90	Rockwool FirePro FireDuct	Various - see facing data page

NOTES - applicable to both tables

1. Base material of the primary duct - plain carbon or stainless steel; galvanised, alu-zinc or black coated surface finish
2. Guidance on minimum duct wall thickness, maximum duct size, appropriate joints etc. for relevant pressure and velocity conditions, is provided in HVCA Spec. - DW/144
3. Cross joints - joint seal may be included or omitted
4. Cross joints - DW 144 (1998): Fig 10 (J3, 4, 5 & 6); Fig 11 drgs 1 & 2 (30 x 1.0 min.), drg 3 (35 x 1.5 min.); Fig 12 drg 1 (25 x 1.0 min.), drg 2 (46 x 0.8 min.), drg 3 n/a
5. General guidance on fastenings and stiffening requirements, appropriate cross joints, seams, supports and hangers etc., is provided in HVCA Specification:- DW/144
6. Longitudinal seam joints must be either Grooved Corner Seam or Pittsburgh Lock Seam - see DW 144 (1998), figs 2 and 3
7. For all ducts in excess of 2000mm wide, incorporate additional drop rods passing through duct and bearer at maximum 2000mm centres along bearer - Rods to support bearer with top of duct being held in position with steel nuts and large steel washers. Weld (or fasten with nuts and large washer) M15 minimum strengthening rods at mid-width of each flanged joint and at 1500mm maximum centres at each penetration point to maintain cross section.
8. Detail of seal at duct penetration through fire resisting walls or floors - see drawings
9. Details of protection to hangers, bearers and flanges - see drawings
10. Details of fixing FirePro Fire Duct system to duct - see drawings
11. DRAWINGS - see above

FIREMASTER FASTWRAP⁺

1. **Type of ductwork system**
 2. Flexible wrap consisting of an alkaline earth silicate fibre blanket completely encapsulated in reinforced aluminium foil which is applied onto existing metal ductwork using stainless steel banding straps.
3. **Manufacturer**
 4. Thermal Ceramics, Tebay Rd, Bromborough CH62 3PH
Tel: 0151-334-4030 www.thermalceramics.com marketing@thermalceramics.co.uk
5. **Scope of Use**
 6. Ventilation ductwork
 7. Kitchen extract ductwork
8. **System Types & Cross Section available**
 9. Add insulating layer to steel duct section [rectangular, circular]
10. **Ductwork orientation**
 11. [i] Horizontal ductwork
 12. [ii] Vertical ductwork
13. **Duct Wall / insulation thickness range**
 14. Minimum duct wall = 0.8mm galvanised steel
 15. Insulation thickness range 38mm to 100mm
16. **Maximum fire resistance to BS 476 Part 24**
 17. 120 mins integrity, stability and insulation
18. **Fire Assessment Report Number**
 19. WF 157967
20. **Appearance**
 21. Reinforced aluminium foil encapsulated insulation wrapped around duct.
22. **Third party accreditation/Quality assurance approvals**
 23. ISO 9001
24. **System Durability**
 25. N/A
26. **Other ductwork applications not addressed above**
 27. Thermal and acoustic insulation

28.

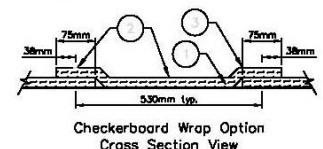
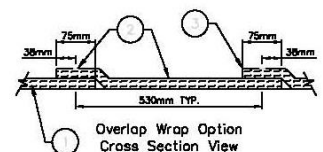
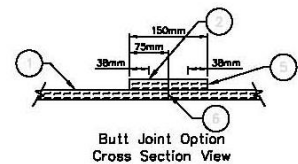
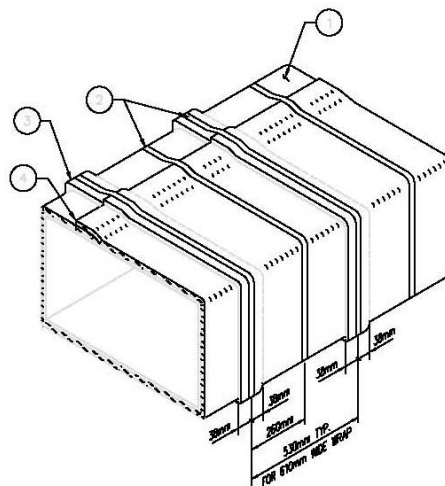

Refer to Design Guide for details	
1	One Layer FireMaster FastWrap+
2	Steel Banding 19mm Wide Min.
3	75mm Min. Longitudinal Overlap
4	75mm Min. Perimeter Overlap
5	150mm Wide FireMaster FastWrap+ Collar
6	Firmly Butted Joint

Note:
The Integrity Of FireMaster Duct Systems
Is Limited To The Quality Of The Installation.

TABLE 1

System Name	FireMaster FastWrap⁺
Supply Company	Thermal Ceramics
Scope of Use /Type	VENTILATION DUCT A / ADD INSULATING LAYER
Fire Assessment Report Number	WF 157967 dated 9 October 2006
Confirm that ductwork system was tested & evaluated to BS 476 Part 24 [ISO 6944]	YES

ORIENTATION: Data for horizontal and vertical duct applications												
DUCT SHAPE: Data for rectangular, circular and oval ducts												
Fire Resistance	Longer Side	Thickness of duct	State if any panel stiffening is required	Max Duct Section Length	Cross Joints Section, Type & Size	Max Spacing of Duct Stiffeners	Section Type and Size of Duct Stiffeners	Are Stiffeners or Tie Rods Needed	Max spacing of hangars and bearers	Thickness of Fire Protection Layer	Fire protection material type & product name	Fixing method for fire protection layers
Stability: 120 mins Integrity: 120 mins Insulation: 120 mins	up to 400mm	steel duct 0.8mm	YES	1.51	J3	0.75	S2	Yes	1.51	38mm	FireMaster FastWrap+	Stainless steel bands
Stability: 120 mins Integrity: 120 mins Insulation: 120 mins	401mm to 1000mm	steel duct 0.8mm	YES	1.51	J4	0.75	S3	Yes	1.51	38mm	FireMaster FastWrap+	Stainless steel bands & Anchor Pins on underside of duct where duct width > 600mm
Stability: 120 mins Integrity: 120 mins Insulation: 120 mins	1001mm to 2000mm	steel duct 1.0 mm	YES	1.51	J5	0.75	S5	Yes	1.51	38mm	FireMaster FastWrap+	Stainless steel bands & Anchor Pins on underside of duct where duct width > 600mm
Stability: 120 mins Integrity: 120 mins Insulation: 120 mins	2001mm to 3000mm	steel duct 1.2 mm	YES	1.51	J6	0.625	S6	Yes	1.51	38mm	FireMaster FastWrap+	Stainless steel bands & Anchor Pins on underside of duct where duct width > 600mm

NOTES

Base Material of Duct	Galvanised Steel minimum thickness 0.8mm 4.8mm dia. steel rivets at 150mm centres or spot welds at 100mm centres. Gasket of FireMaster 607 Paper 15mm wide x 3mm thick or Fenland Fire intumescent tape 15mm wide x 5mm thick
Cross Joint Fixings	Pittsburgh Lock or Grooved corner (RAS) and flanged cross joints.
Longitudinal joints	None
Additional Non- Fire Protection Layers to Duct	None
Detail of Penetration Seal	FireMaster Expanding Felt or Offcuts of FastWrap+ packed into gap with covering of Hilti CP601 S mastic. See Drawing FM CAD D-06 for details
Drawings	FM CAD D-01 : General Arrangement of FireMaster FastWrap+ System FM CAD D-02: Access Door Insulation FM CAD D-03: 2-Sided Ducts - Layout of FireMaster FastWrap+ FM CAD D-04: 3-Sided Ducts - Layout of FireMaster FastWrap+ FM CAD D-05: Vertical Ducts - Installation of FireMaster FastWrap+ FM CAD D-06: Penetration Seal Details FM CAD D-07: Fixing Pin layout on underside of ducts > 600mm wide

TABLE 2

System Name **FireMaster FastWrap⁺**
 Supply Company **Thermal Ceramics**
 Scope of Use /Type **VENTILATION DUCT A / ADD INSULATING LAYER**
 Fire Assessment Report Number **WF 157967 dated 9 October 2006**
 Confirm that ductwork system was tested & evaluated to BS 476 Part 24 [ISO 6944] **YES**

ORIENTATION: Data for horizontal and vertical duct applications												
DUCT SHAPE: Data for rectangular, circular and oval ducts												
Fire Resistance	Longer Side	Thickness of duct	State if any panel stiffening is required	Max Duct Section Length	Cross Joints Section, Type & Size	Max Spacing of Duct Stiffeners	Section Type and Size of Duct Stiffeners	Are Stiffeners or Tie Rods Needed	Maximum Spacing of hangars and bearers	Thickness of Fire Protection Layer	Fire protection material type & product name	Fixing method for fire protection layers
Stability: 120 mins Integrity: 120 mins Insulation: 120 mins	up to 400mm	steel duct 0.8mm	YES	1.51	J2	0.75	S2	Yes	1.51	38mm	FireMaster FastWrap+	Stainless steel bands
Stability: 120 mins Integrity: 120 mins Insulation: 120 mins	401mm to 1000mm	steel duct 0.8mm	YES	1.51	J3	0.75	S3	Yes	1.51	38mm	FireMaster FastWrap+	Stainless steel bands & Anchor Pins on underside of duct where duct width > 600mm
Stability: 120 mins Integrity: 120 mins Insulation: 120 mins	1001mm to 2000mm	steel duct 1.0 mm	YES	1.51	J5	0.75	S5	Yes	1.51	38mm	FireMaster FastWrap+	Stainless steel bands & Anchor Pins on underside of duct where duct width > 600mm
Stability: 120 mins Integrity: 120 mins Insulation: 120 mins	2001mm to 3000mm	steel duct 1.2 mm	YES	1.51	J6	0.625	S6	Yes	1.51	38mm	FireMaster FastWrap+	Stainless steel bands & Anchor Pins on underside of duct where duct width > 600mm

NOTES

Base Material of Duct Galvanised Steel minimum thickness 0.8mm
 4.8mm dia. steel rivets at 150mm centres or spot welds at 100mm centres. Gasket of FireMaster 607 Paper 15mm wide x 3mm thick or Fenland Fire intumescent tape 15mm wide x 5mm thick

Cross Joint Fixings Pittsburgh Lock or Grooved corner (RAS) and flanged cross joints.

Longitudinal joints None

Additional Non- Fire Protection Layers to Duct FireMaster Expanding Felt or Offcuts of FastWrap+ packed into gap with covering of Hilti CP601 S mastic. See Drawing FM CAD D-06 for details

Detail of Penetration Seal FM CAD D-01 : General Arrangement of FireMaster FastWrap+ System
 FM CAD D-02: Access Door Insulation
 FM CAD D-03: 2-Sided Ducts - Layout of FireMaster FastWrap+
 FM CAD D-04: 3-Sided Ducts - Layout of FireMaster FastWrap+
 FM CAD D-05: Vertical Ducts - Installation of FireMaster FastWrap+
 FM CAD D-06: Penetration Seal Details
 FM CAD D-07: Fixing Pin layout on underside of ducts > 600mm wide

TABLE 3

System Name **FireMaster FastWrap⁺**
 Supply Company **Thermal Ceramics**
 Scope of Use /Type **VENTILATION DUCT A / ADD INSULATING LAYER**
 Fire Assessment Report Number **WF 157967 dated 9 October 2006**
 Confirm that ductwork system was tested & evaluated to BS 476 Part 24 [ISO 6944] **YES**
 Orientation **Vertical and Horizontal**
 Duct Shape **Circular**

ORIENTATION: Data for horizontal and vertical duct applications												
DUCT SHAPE: Data for rectangular, circular and oval ducts												
Fire Resistance	Diameter	Thickness of duct	State if any panel stiffening is required	Max Duct Section Length	Cross Joints Section, Type & Size	Max Spacing of Duct Stiffeners	Section Type and Size of Duct Stiffeners	Are Stiffeners or Tie Rods Needed	Maximum Spacing of hangers and bearers	Thickness of Fire Protection Layer	Fire protection material type & product name	Fixing method for fire protection layers
Stability: 120 mins Integrity: 120 mins Insulation: 120 mins	Up to 0.2	steel duct 0.8mm	YES	1.51 straight Seam or 3.0 spiral	Socket & spigot with steel rivets			No	1.51	38mm	FireMaster FastWrap+	Stainless steel bands & Anchor Pins on underside of duct where duct diameter > 200mm & at 300mm centres where bands cannot be fitted
Stability: 120 mins Integrity: 120 mins Insulation: 120 mins	0.201 to 0.5	steel duct 0.8mm	YES	1.51 straight Seam or 3.0 spiral	Spiral Mate			No	1.51	38mm	FireMaster FastWrap+	Stainless steel bands & Anchor Pins on underside of duct where duct diameter > 200mm & at 300mm centres where bands cannot be fitted
Stability: 120 mins Integrity: 120 mins Insulation: 120 mins	0.501 to 0.71	steel duct 1.0 mm	YES	1.51 straight Seam or 3.0 spiral	Spiral Mate or 40mm x 40mm x 5mm RSA			No	1.51	38mm	FireMaster FastWrap+	Stainless steel bands & Anchor Pins on underside of duct where duct diameter > 200mm & at 300mm centres where bands cannot be fitted
Stability: 120 mins Integrity: 120 mins Insulation: 120 mins	0.711 to 1.0	steel duct 1.2 mm	YES	1.51 straight Seam or 3.0 spiral	Spiral Mate or 40mm x 40mm x 5mm RSA	1m	40mm x 40mm x 4mm RSA	Yes	1.51	38mm	FireMaster FastWrap+	Stainless steel bands & Anchor Pins on underside of duct where duct diameter > 200mm & at 300mm centres where bands cannot be fitted
Stability: 120 mins Integrity: 120 mins Insulation: 120 mins	1.001 to 1.25	steel duct 1.2 mm	YES	3.0 spiral	Spiral Mate or 40mm x 40mm x 5mm RSA	1m	50mm x 50mm x 5mm RSA	Yes	1.51	38mm	FireMaster FastWrap+	Stainless steel bands & Anchor Pins on underside of duct where duct diameter > 200mm & at 300mm centres where bands cannot be fitted

NOTES

Base Material of Duct Galvanised Steel minimum thickness 0.8mm
 Cross Joint Fixings 4.8mm dia. steel rivets at 150mm centres or spot welds at 100mm centres. Gasket of FireMaster 607 Paper 15mm wide x 3mm thick or Fenland Fire intumescent tape 15mm wide x 5mm thick
 Longitudinal joints Straight Seam equivalent to Pittsburgh Lock or Spiral Seam equivalent to grooved corner (RAS) used in rectangular ducts
 Additional Non- Fire Protection Layers to Duct None
 Detail of Penetration Seal FireMaster Expanding Felt or Offcuts of FastWrap+ packed into gap with covering of Hilti CP601 S mastic. See Drawing FM CAD D-06 for details
 Drawings FM CAD D-01 : General Arrangement of FireMaster FastWrap+ System
 FM CAD D-02: Access Door Insulation
 FM CAD D-03: 2-Sided Ducts - Layout of FireMaster FastWrap+
 FM CAD D-04: 3-Sided Ducts - Layout of FireMaster FastWrap+
 FM CAD D-05: Vertical Ducts - Installation of FireMaster FastWrap+
 FM CAD D-06: Penetration Seal Details

TABLE 4

System Name	FireMaster FastWrap⁺
Supply Company	Thermal Ceramics
Scope of Use /Type	VENTILATION DUCT B / ADD INSULATING LAYER
Fire Assessment Report Number	WF 157967 dated 9 October 2006
Confirm that ductwork system was tested & evaluated to BS 476 Part 24 [ISO 6944]	YES
Orientation	Vertical and Horizontal
Duct Shape	Rectangular

ORIENTATION: Data for horizontal and vertical duct applications

DUCT SHAPE: Data for rectangular, circular and oval ducts

Fire Resistance	Longer Side	Thickness of duct	State if any panel stiffening is required	Max Duct Section Length	Cross Joints Section, Type & Size	Max Spacing of Duct Stiffeners	Section Type and Size of Duct Stiffeners	Are Stiffeners or Tie Rods Needed	Maximum Spacing of hangers and bearers	Thickness of Fire Protection Layer	Fire protection material type & product name	Fixing method for fire protection layers
Stability: 120 mins Integrity: 120 mins Insulation: 120 mins	up to 400mm	steel duct 0.8mm	YES	1.51	J3	0.75	S2	Yes	1.51	50mm	FireMaster FastWrap+	Stainless steel bands
Stability: 120 mins Integrity: 120 mins Insulation: 120 mins	401mm to 1000mm	steel duct 0.8mm	YES	1.51	J4	0.75	S3	Yes	1.51	50mm	FireMaster FastWrap+	Stainless steel bands & Anchor Pins on underside of duct where duct width > 600mm
Stability: 120 mins Integrity: 120 mins Insulation: 120 mins	1001mm to 2000mm	steel duct 1.0 mm	YES	1.51	J5	0.75	S5	Yes	1.51	50mm	FireMaster FastWrap+	Stainless steel bands & Anchor Pins on underside of duct where duct width > 600mm
Stability: 120 mins Integrity: 120 mins Insulation: 120 mins	2001mm to 3000mm	steel duct 1.2 mm	YES	1.51	J6	0.625	S6	Yes	1.51	50mm	FireMaster FastWrap+	Stainless steel bands & Anchor Pins on underside of duct where duct width > 600mm

NOTES

Base Material of Duct	Galvanised Steel minimum thickness 0.8mm
Cross Joint Fixings	4.8mm dia. steel rivets at 150mm centres or spot welds at 100mm centres. Gasket of FireMaster 607 Paper 15mm wide x 3mm thick or Fenland Fire intumescent tape 15mm wide x 5mm thick
Longitudinal joints	Pittsburgh Lock or Grooved corner (RAS) and flanged cross joints.
Additional Non- Fire Protection Layers to Duct	None
Detail of Penetration Seal	FireMaster Expanding Felt or Offcuts of FastWrap+ packed into gap with covering of Hilti CP601 S mastic. See Drawing FM CAD D-06 for details
Drawings	FM CAD D-01 : General Arrangement of FireMaster FastWrap+ System FM CAD D-02: Access Door Insulation FM CAD D-03: 2-Sided Ducts - Layout of FireMaster FastWrap+ FM CAD D-04: 3-Sided Ducts - Layout of FireMaster FastWrap+ FM CAD D-05: Vertical Ducts - Installation of FireMaster FastWrap+ FM CAD D-06: Penetration Seal Details

FM CAD D-07: Fixing Pin layout on underside of ducts > 600mm wide

TABLE 5

System Name **FireMaster FastWrap⁺**
 Supply Company **Thermal Ceramics**
 Scope of Use /Type **VENTILATION DUCT B / ADD INSULATING LAYER**
 Fire Assessment Report Number **WF 157967 dated 9 October 2006**
 Confirm that ductwork system was tested & evaluated to BS 476 Part 24 [ISO 6944] **YES**

ORIENTATION: Data for horizontal and vertical duct applications												
DUCT SHAPE: Data for rectangular, circular and oval ducts												
Fire Resistance	Longer Side	Thickness of duct	State if any panel stiffening is required	Max Duct Section Length	Cross Joints Section, Type & Size	Max Spacing of Duct Stiffeners	Section Type and Size of Duct Stiffeners	Are Stiffeners or Tie Rods Needed	Maximum Spacing of hangars and bearers	Thickness of Fire Protection Layer	Fire protection material type & product name	Fixing method for fire protection layers
Stability: 120 mins Integrity: 120 mins Insulation: 60 mins	up to 400mm	steel duct 0.8mm	YES	1.51	J3	0.75	S2	Yes	1.51	88mm	FireMaster FastWrap+	Stainless steel bands
Stability: 120 mins Integrity: 120 mins Insulation: 60 mins	401mm to 1000mm	steel duct 0.8mm	YES	1.51	J4	0.75	S3	Yes	1.51	88mm	FireMaster FastWrap+	Stainless steel bands & Anchor Pins on underside of duct where duct width > 600mm
Stability: 120 mins Integrity: 120 mins Insulation: 60 mins	1001mm to 2000mm	steel duct 1.0 mm	YES	1.51	J5	0.75	S5	Yes	1.51	88mm	FireMaster FastWrap+	Stainless steel bands & Anchor Pins on underside of duct where duct width > 600mm
Stability: 120 mins Integrity: 120 mins Insulation: 60 mins	2001mm to 3000mm	steel duct 1.2 mm	YES	1.51	J6	0.625	S6	Yes	1.51	88mm	FireMaster FastWrap+	Stainless steel bands & Anchor Pins on underside of duct where duct width > 600mm

NOTES

Base Material of Duct Galvanised Steel minimum thickness 0.8mm
 Cross Joint Fixings 4.8mm dia. steel rivets at 150mm centres or spot welds at 100mm centres. Gasket of FireMaster 607 Paper 15mm wide x 3mm thick or Fenland Fire intumescent tape 15mm wide x 5mm thick
 Longitudinal joints Pittsburgh Lock or Grooved corner (RAS) and flanged cross joints.
 Additional Non- Fire Protection Layers to Duct None
 Detail of Penetration Seal FireMaster Expanding Felt or Offcuts of FastWrap+ packed into gap with covering of Hilti CP601 S mastic. See Drawing FM CAD D-06 for details
 Drawings FM CAD D-01 : General Arrangement of FireMaster FastWrap+ System
 FM CAD D-02: Access Door Insulation
 FM CAD D-03: 2-Sided Ducts - Layout of FireMaster FastWrap+
 FM CAD D-04: 3-Sided Ducts - Layout of FireMaster FastWrap+
 FM CAD D-05: Vertical Ducts - Installation of FireMaster FastWrap+
 FM CAD D-06: Penetration Seal Details
 FM CAD D-07: Fixing Pin layout on underside of ducts > 600mm wide

TABLE 6

System Name	FireMaster FastWrap⁺
Supply Company	Thermal Ceramics
Scope of Use /Type	VENTILATION DUCT B / ADD INSULATING LAYER
Fire Assessment Report Number	WF 157967 dated 9 October 2006
Confirm that ductwork system was tested & evaluated to BS 476 Part 24 [ISO 6944]	YES

ORIENTATION: Data for horizontal and vertical duct applications												
DUCT SHAPE: Data for rectangular, circular and oval ducts												
Fire Resistance	Longer Side	Thickness of duct	State if any panel stiffening is required	Max Duct Section Length	Cross Joints Section, Type & Size	Max Spacing of Duct Stiffeners	Section Type and Size of Duct Stiffeners	Are Stiffeners or Tie Rods Needed	Maximum Spacing of hangars and bearers	Thickness of Fire Protection Layer	Fire protection material type & product name	Fixing method for fire protection layers
Stability: 60 mins Integrity: 60 mins Insulation: 30 mins	up to 400mm	steel duct 0.8mm	YES	1.51	J2	0.75	S2	Yes	1.51	50mm	FireMaster FastWrap+	Stainless steel bands
Stability: 60 mins Integrity: 60 mins Insulation: 30 mins	401mm to 1000mm	steel duct 0.8mm	YES	1.51	J3	0.75	S3	Yes	1.51	50mm	FireMaster FastWrap+	Stainless steel bands & Anchor Pins on underside of duct where duct width > 600mm
Stability: 60 mins Integrity: 60 mins Insulation: 30 mins	1001mm to 2000mm	steel duct 1.0 mm	YES	1.51	J5	0.75	S5	Yes	1.51	50mm	FireMaster FastWrap+	Stainless steel bands & Anchor Pins on underside of duct where duct width > 600mm
Stability: 60 mins Integrity: 60 mins Insulation: 30 mins	2001mm to 3000mm	steel duct 1.2 mm	YES	1.51	J6	0.625	S6	Yes	1.51	50mm	FireMaster FastWrap+	Stainless steel bands & Anchor Pins on underside of duct where duct width > 600mm

NOTES

Base Material of Duct	Galvanised Steel minimum thickness 0.8mm
Cross Joint Fixings	4.8mm dia. steel rivets at 150mm centres or spot welds at 100mm centres. Gasket of FireMaster 607 Paper 15mm wide x 3mm thick or Fenland Fire intumescent tape 15mm wide x 5mm thick
Longitudinal joints	Pittsburgh Lock or Grooved corner (RAS) and flanged cross joints.
Additional Non- Fire Protection Layers to Duct	None
Detail of Penetration Seal	FireMaster Expanding Felt or Offcuts of FastWrap+ packed into gap with covering of Hilti CP601 S mastic. See Drawing FM CAD D-06 for details
Drawings	FM CAD D-01 : General Arrangement of FireMaster FastWrap+ System FM CAD D-02: Access Door Insulation FM CAD D-03: 2-Sided Ducts - Layout of FireMaster FastWrap+ FM CAD D-04: 3-Sided Ducts - Layout of FireMaster FastWrap+ FM CAD D-05: Vertical Ducts - Installation of FireMaster FastWrap+ FM CAD D-06: Penetration Seal Details FM CAD D-07: Fixing Pin layout on underside of ducts > 600mm wide

TABLE 7

System Name **FireMaster FastWrap⁺**
 Supply Company **Thermal Ceramics**
 Scope of Use /Type **VENTILATION DUCT B / ADD INSULATING LAYER**
 Fire Assessment Report Number **WF 157967 dated 9 October 2006**
 Confirm that ductwork system was tested & evaluated to BS 476 Part 24 [ISO 6944] **YES**

ORIENTATION: Data for horizontal and vertical duct applications												
DUCT SHAPE: Data for rectangular, circular and oval ducts												
Fire Resistance	Longer Side	Thickness of duct	State if any panel stiffening is required	Max Duct Section Length	Cross Joints Section, Type & Size	Max Spacing of Duct Stiffeners	Section Type and Size of Duct Stiffeners	Are Stiffeners or Tie Rods Needed	Maximum Spacing of hangars and bearers	Thickness of Fire Protection Layer	Fire protection material type & product name	Fixing method for fire protection layers
Stability: 60 mins Integrity: 60 mins Insulation: 60 mins	up to 400mm	steel duct 0.8mm	YES	1.51	J2	0.75	S2	Yes	1.51	88mm	FireMaster FastWrap+	Stainless steel bands
Stability: 60 mins Integrity: 60 mins Insulation: 60 mins	401mm to 1000mm	steel duct 0.8mm	YES	1.51	J3	0.75	S3	Yes	1.51	88mm	FireMaster FastWrap+	Stainless steel bands & Anchor Pins on underside of duct where duct width > 600mm
Stability: 60 mins Integrity: 60 mins Insulation: 60 mins	1001mm to 2000mm	steel duct 1.0 mm	YES	1.51	J5	0.75	S5	Yes	1.51	88mm	FireMaster FastWrap+	Stainless steel bands & Anchor Pins on underside of duct where duct width > 600mm
Stability: 60 mins Integrity: 60 mins Insulation: 60 mins	2001mm to 3000mm	steel duct 1.2 mm	YES	1.51	J6	0.625	S6	Yes	1.51	88mm	FireMaster FastWrap+	Stainless steel bands & Anchor Pins on underside of duct where duct width > 600mm

NOTES

Base Material of Duct Galvanised Steel minimum thickness 0.8mm
 Cross Joint Fixings 4.8mm dia. steel rivets at 150mm centres or spot welds at 100mm centres. Gasket of FireMaster 607 Paper 15mm wide x 3mm thick or Fenland Fire intumescent tape 15mm wide x 5mm thick
 Longitudinal joints Pittsburgh Lock or Grooved corner (RAS) and flanged cross joints.
 Additional Non- Fire Protection Layers to Duct None
 Detail of Penetration Seal FireMaster Expanding Felt or Offcuts of FastWrap+ packed into gap with covering of Hilti CP601 S mastic. See Drawing FM CAD D-06 for details
 Drawings FM CAD D-01 : General Arrangement of FireMaster FastWrap+ System
 FM CAD D-02: Access Door Insulation
 FM CAD D-03: 2-Sided Ducts - Layout of FireMaster FastWrap+
 FM CAD D-04: 3-Sided Ducts - Layout of FireMaster FastWrap+
 FM CAD D-05: Vertical Ducts - Installation of FireMaster FastWrap+
 FM CAD D-06: Penetration Seal Details
 FM CAD D-07: Fixing Pin layout on underside of ducts > 600mm wide

TABLE 8

System Name

FireMaster FastWrap⁺

Supply Company

Thermal Ceramics

Scope of Use /Type

VENTILATION DUCT B / ADD INSULATING LAYER

Fire Assessment Report Number

WF 157967 dated 9 October 2006

Confirm that ductwork system was tested & evaluated to BS 476 Part 24 [ISO 6944]

YES

ORIENTATION: Data for horizontal and vertical duct applications												
DUCT SHAPE: Data for rectangular, circular and oval ducts												
Fire Resistance	Diameter	Thickness of duct	State if any panel stiffening is required	Max Duct Section Length	Cross Joints Section, Type & Size	Max Spacing of Duct Stiffeners	Section Type and Size of Duct Stiffeners	Are Stiffeners or Tie Rods Needed	Maximum Spacing of hangers and bearers	Thickness of Fire Protection Layer	Fire protection material type & product name	Fixing method for fire protection layers
Stability: 120 mins Integrity: 120 mins Insulation: 60 mins	Up to 0.2	steel duct 0.8mm	YES	1.51 straight seam or 3.0 spiral	Socket & spigot with steel rivets			No	1.51	88mm	FireMaster FastWrap+	Stainless steel bands & Anchor Pins on underside of duct where duct diameter > 200mm & at 300mm centres where bands cannot be fitted
Stability: 120 mins Integrity: 120 mins Insulation: 60 mins	0.201 to 0.5	steel duct 0.8mm	YES	1.51 straight seam or 3.0 spiral	Spiral Mate			No	1.51	88mm	FireMaster FastWrap+	Stainless steel bands & Anchor Pins on underside of duct where duct diameter > 200mm & at 300mm centres where bands cannot be fitted
Stability: 120 mins Integrity: 120 mins Insulation: 60 mins	0.501 to 0.71	steel duct 1.0mm	YES	1.51 straight seam or 3.0 spiral	Spiral Mate or 40mm x 40mm x 5mm RSA			No	1.51	88mm	FireMaster FastWrap+	Stainless steel bands & Anchor Pins on underside of duct where duct diameter > 200mm & at 300mm centres where bands cannot be fitted
Stability: 120 mins Integrity: 120 mins Insulation: 60 mins	0.711 to 1.0	steel duct 1.2mm	YES	1.51 straight seam or 3.0 spiral	Spiral Mate or 40mm x 40mm x 5mm RSA	1m	40mm x 40mm x 4mm RSA	Yes	1.51	88mm	FireMaster FastWrap+	Stainless steel bands & Anchor Pins on underside of duct where duct diameter > 200mm & at 300mm centres where bands cannot be fitted
Stability: 120 mins Integrity: 120 mins Insulation: 60 mins	1.001 to 1.25	steel duct 1.2mm	YES	3.0 spiral	Spiral Mate or 40mm x 40mm x 5mm RSA	1m	50mm x 50mm x 5mm RSA	Yes	1.51	88mm	FireMaster FastWrap+	Stainless steel bands & Anchor Pins on underside of duct where duct diameter > 200mm & at 300mm centres where bands cannot be fitted

NOTES

Base Material of Duct

Galvanised Steel minimum thickness 0.8mm

Cross Joint Fixings

4.8mm dia. steel rivets at 150mm centres or spot welds at 100mm centres. Gasket of FireMaster 607 Paper 15mm wide x 3mm thick or Fenland Fire intumescent tape 15mm wide x 5mm thick

Longitudinal joints

Straight Seam equivalent to Pittsburgh Lock or Spiral Seam equivalent to grooved corner (RAS) used in rectangular ducts

Additional Non- Fire Protection Layers to Duct

None

Detail of Penetration Seal

FireMaster Expanding Felt or Offcuts of FastWrap+ packed into gap with covering of Hilti CP601 S mastic. See Drawing FM CAD D-06 for details

Drawings

FM CAD D-01 : General Arrangement of FireMaster FastWrap+ System

FM CAD D-02: Access Door Insulation

FM CAD D-03: 2-Sided Ducts - Layout of FireMaster FastWrap+

FM CAD D-04: 3-Sided Ducts - Layout of FireMaster FastWrap+

FM CAD D-05: Vertical Ducts - Installation of FireMaster FastWrap+

FM CAD D-06: Penetration Seal Details

FM CAD D-07: Fixing Pin layout on underside of ducts > 600mm wide

TABLE 9

System Name

FireMaster FastWrap⁺

Supply Company

Thermal Ceramics

Scope of Use /Type

VENTILATION DUCT B / ADD INSULATING LAYER

Fire Assessment Report Number

WF 157967 dated 9 October 2006

Confirm that ductwork system was tested & evaluated to BS 476 Part 24 [ISO 6944] YES

ORIENTATION: Data for horizontal and vertical duct applications												
DUCT SHAPE: Data for rectangular, circular and oval ducts												
Fire Resistance	Diameter	Thickness of duct	State if any panel stiffening is required	Max Duct Section Length	Cross Joints Section, Type & Size	Max Spacing of Duct Stiffeners	Section Type and Size of Duct Stiffeners	Are Stiffeners or Tie Rods Needed	Maximum Spacing of hangars and bearers	Thickness of Fire Protection Layer	Fire protection material type & product name	Fixing method for fire protection layers
Stability: 120 mins Integrity: 120 mins Insulation: 30 mins	Up to 0.2	steel duct 0.8mm	YES	1.51 straight seam or 3.0 spiral	Socket & spigot with steel rivets			No	1.51	50mm	FireMaster FastWrap+	Stainless steel bands & Anchor Pins on underside of duct where duct diameter > 200mm & at 300mm centres where bands cannot be fitted
Stability: 120 mins Integrity: 120 mins Insulation: 30 mins	0.201 to 0.5	steel duct 0.8mm	YES	1.51 straight seam or 3.0 spiral	Spiral Mate			No	1.51	50mm	FireMaster FastWrap+	Stainless steel bands & Anchor Pins on underside of duct where duct diameter > 200mm & at 300mm centres where bands cannot be fitted
Stability: 120 mins Integrity: 120 mins Insulation: 30 mins	0.501 to 0.71	steel duct 1.0 mm	YES	1.51 straight seam or 3.0 spiral	Spiral Mate or 40mm x 40mm x 5mm RSA			No	1.51	50mm	FireMaster FastWrap+	Stainless steel bands & Anchor Pins on underside of duct where duct diameter > 200mm & at 300mm centres where bands cannot be fitted
Stability: 120 mins Integrity: 120 mins Insulation: 30 mins	0.711 to 1.0	steel duct 1.2 mm	YES	1.51 straight seam or 3.0 spiral	Spiral Mate or 40mm x 40mm x 5mm RSA	1m	40mm x 40mm x 4mm RSA	Yes	1.51	50mm	FireMaster FastWrap+	Stainless steel bands & Anchor Pins on underside of duct where duct diameter > 200mm & at 300mm centres where bands cannot be fitted
Stability: 120 mins Integrity: 120 mins Insulation: 30 mins	1.001 to 1.25	steel duct 1.2 mm	YES	3.0 spiral	Spiral Mate or 40mm x 40mm x 5mm RSA	1m	50mm x 50mm x 5mm RSA	Yes	1.51	50mm	FireMaster FastWrap+	Stainless steel bands & Anchor Pins on underside of duct where duct diameter > 200mm & at 300mm centres where bands cannot be fitted

NOTES

Base Material of Duct

Galvanised Steel minimum thickness 0.8mm

Cross Joint Fixings

4.8mm dia. steel rivets at 150mm centres or spot welds at 100mm centres. Gasket of FireMaster 607 Paper 15mm wide x 3mm thick or Fenland Fire intumescent tape 15mm wide x 5mm thick

Longitudinal joints

Straight Seam equivalent to Pittsburgh Lock or Spiral Seam equivalent to grooved corner (RAS) used in rectangular ducts

Additional Non- Fire Protection Layers to Duct

None

Detail of Penetration Seal

FireMaster Expanding Felt or Offcuts of FastWrap+ packed into gap with covering of Hilti CP601 S mastic. See Drawing FM CAD D-06 for details

Drawings

FM CAD D-01 : General Arrangement of FireMaster FastWrap+ System

FM CAD D-02: Access Door Insulation

FM CAD D-03: 2-Sided Ducts - Layout of FireMaster FastWrap+

FM CAD D-04: 3-Sided Ducts - Layout of FireMaster FastWrap+

FM CAD D-05: Vertical Ducts - Installation of FireMaster FastWrap+

FM CAD D-06: Penetration Seal Details

TABLE 10

System Name	FireMaster FastWrap⁺
Supply Company	Thermal Ceramics
Scope of Use /Type	KITCHEN EXTRACT DUCT / ADD INSULATING LAYER
Fire Assessment Report Number	WF 157967 dated 9 October 2006
Confirm that ductwork system was tested & evaluated to BS 476 Part 24 [ISO 6944]	YES

ORIENTATION: Data for horizontal and vertical duct applications												
DUCT SHAPE: Data for rectangular, circular and oval ducts												
Fire Resistance	Longer Side	Thickness of duct	State if any panel stiffening is required	Max Duct Section Length	Cross Joints Section, Type & Size	Max Spacing of Duct Stiffeners	Section Type and Size of Duct Stiffeners	Are Stiffeners or Tie Rods Needed	Maximum Spacing of hangars and bearers	Thickness of Fire Protection Layer	Fire protection material type & product name	Fixing method for fire protection layers
Stability: 60 mins Integrity: 60 mins Insulation: 60 mins	up to 400mm	steel duct 0.8mm	YES	1.51	J2	0.75	S2	Yes	1.51	100mm	FireMaster FastWrap+	Stainless steel bands
Stability: 60 mins Integrity: 60 mins Insulation: 60 mins	401mm to 1000mm	steel duct 0.8mm	YES	1.51	J3	0.75	S3	Yes	1.51	100mm	FireMaster FastWrap+	Stainless steel bands & Anchor Pins on underside of duct where duct width > 400mm
Stability: 60 mins Integrity: 60 mins Insulation: 60 mins	1001mm to 2000mm	steel duct 1.0 mm	YES	1.51	J5	0.75	S5	Yes	1.51	100mm	FireMaster FastWrap+	Stainless steel bands & Anchor Pins on underside of duct where duct width > 400mm
Stability: 60 mins Integrity: 60 mins Insulation: 60 mins	2001mm to 3000mm	steel duct 1.2 mm	YES	1.51	J6	0.625	S6	Yes	1.51	100mm	FireMaster FastWrap+	Stainless steel bands & Anchor Pins on underside of duct where duct width > 400mm

NOTES

Base Material of Duct	Galvanised Steel minimum thickness 0.8mm
Cross Joint Fixings	4.8mm dia. steel rivets at 150mm centres or spot welds at 100mm centres. Gasket of FireMaster 607 Paper 15mm wide x 3mm thick or Fenland Fire intumescent tape 15mm wide x 5mm thick
Longitudinal joints	Pittsburgh Lock or Grooved corner (RAS) and flanged cross joints.
Additional Non- Fire Protection Layers to Duct	None
Detail of Penetration Seal	FireMaster Expanding Felt or Offcuts of FastWrap+ packed into gap with covering of Hilti CP601 S mastic. See Drawing FM CAD D-06 for details
Drawings	FM CAD D-01 : General Arrangement of FireMaster FastWrap+ System FM CAD D-02: Access Door Insulation FM CAD D-03: 2-Sided Ducts - Layout of FireMaster FastWrap+ FM CAD D-04: 3-Sided Ducts - Layout of FireMaster FastWrap+ FM CAD D-05: Vertical Ducts - Installation of FireMaster FastWrap+ FM CAD D-06: Penetration Seal Details FM CAD D-07: Fixing Pin layout on underside of ducts > 600mm wide

TABLE 11

System Name

FireMaster FastWrap⁺

Supply Company

Thermal Ceramics

Scope of Use /Type

KITCHEN EXTRACT DUCT / ADD INSULATING LAYER

Fire Assessment Report Number

WF 157967 dated 9 October 2006

Confirm that ductwork system was tested & evaluated to BS 476 Part 24 [ISO 6944]

YES

ORIENTATION: Data for horizontal and vertical duct applications												
DUCT SHAPE: Data for rectangular, circular and oval ducts												
Fire Resistance	Longer Side	Thickness of duct	State if any panel stiffening is required	Max Duct Section Length	Cross Joints Section, Type & Size	Max Spacing of Duct Stiffeners	Section Type and Size of Duct Stiffeners	Are Stiffeners or Tie Rods Needed	Maximum Spacing of hangars and bearers	Thickness of Fire Protection Layer	Fire protection material type & product name	Fixing method for fire protection layers
Stability: 60 mins Integrity: 60 mins Insulation: 30 mins	up to 400mm	steel duct 0.8mm	YES	1.51	J2	0.75	S2	Yes	1.51	38mm	FireMaster FastWrap+	Stainless steel bands
Stability: 60 mins Integrity: 60 mins Insulation: 30 mins	401mm to 1000mm	steel duct 0.8mm	YES	1.51	J3	0.75	S3	Yes	1.51	38mm	FireMaster FastWrap+	Stainless steel bands & Anchor Pins on underside of duct where duct width > 400mm
Stability: 60 mins Integrity: 60 mins Insulation: 30 mins	1001mm to 2000mm	steel duct 1.0 mm	YES	1.51	J5	0.75	S5	Yes	1.51	38mm	FireMaster FastWrap+	Stainless steel bands & Anchor Pins on underside of duct where duct width > 400mm
Stability: 60 mins Integrity: 60 mins Insulation: 30 mins	2001mm to 3000mm	steel duct 1.2 mm	YES	1.51	J6	0.625	S6	Yes	1.51	38mm	FireMaster FastWrap+	Stainless steel bands & Anchor Pins on underside of duct where duct width > 400mm

NOTES

Base Material of Duct

Galvanised Steel minimum thickness 0.8mm

Cross Joint Fixings

4.8mm dia. steel rivets at 150mm centres or spot welds at 100mm centres. Gasket of FireMaster 607 Paper 15mm wide x 3mm thick or Fenland Fire intumescent tape 15mm wide x 5mm thick

Longitudinal joints

Pittsburgh Lock or Grooved corner (RAS) and flanged cross joints.

Additional Non- Fire Protection Layers to Duct

None

Detail of Penetration Seal

FireMaster Expanding Felt or Offcuts of FastWrap+ packed into gap with covering of Hilti CP601 S mastic. See Drawing FM CAD D-06 for details

Drawings

FM CAD D-01 : General Arrangement of FireMaster FastWrap+ System

FM CAD D-02: Access Door Insulation

FM CAD D-03: 2-Sided Ducts - Layout of FireMaster FastWrap+

FM CAD D-04: 3-Sided Ducts - Layout of FireMaster FastWrap+

FM CAD D-05: Vertical Ducts - Installation of FireMaster FastWrap+

FM CAD D-06: Penetration Seal Details

FM CAD D-07: Fixing Pin layout on underside of ducts > 600mm wide

TABLE 12

System Name **FireMaster FastWrap⁺**
 Supply Company **Thermal Ceramics**
 Scope of Use /Type **KITCHEN EXTRACT DUCT / ADD INSULATING LAYER**
 Fire Assessment Report Number **WF 157967 dated 9 October 2006**
 Confirm that ductwork system was tested & evaluated to BS 476 Part 24 [ISO 6944] **YES**

ORIENTATION: Data for horizontal and vertical duct applications												
DUCT SHAPE: Data for rectangular, circular and oval ducts												
Fire Resistance	Longer Side	Thickness of duct	State if any panel stiffening is required	Max Duct Section Length	Cross Joints Section, Type & Size	Max Spacing of Duct Stiffeners	Section Type and Size of Duct Stiffeners	Are Stiffeners or Tie Rods Needed	Maximum Spacing of hangars and bearers	Thickness of Fire Protection Layer	Fire protection material type & product name	Fixing method for fire protection layers
Stability: 120 mins Integrity: 120 mins Insulation: 60 mins	up to 400mm	steel duct 0.8mm	YES	1.51	J3	0.75	S2	Yes	1.51	100mm	FireMaster FastWrap+	Stainless steel bands
Stability: 120 mins Integrity: 120 mins Insulation: 60 mins	401mm to 1000mm	steel duct 0.8mm	YES	1.51	J4	0.75	S3	Yes	1.51	100mm	FireMaster FastWrap+	Stainless steel bands & Anchor Pins on underside of duct where duct width > 400mm
Stability: 120 mins Integrity: 120 mins Insulation: 60 mins	1001mm to 2000mm	steel duct 1.0 mm	YES	1.51	J5	0.75	S5	Yes	1.51	100mm	FireMaster FastWrap+	Stainless steel bands & Anchor Pins on underside of duct where duct width > 400mm
Stability: 120 mins Integrity: 120 mins Insulation: 60 mins	2001mm to 3000mm	steel duct 1.2 mm	YES	1.51	J6	0.625	S6	Yes	1.51	100mm	FireMaster FastWrap+	Stainless steel bands & Anchor Pins on underside of duct where duct width > 400mm

NOTES

Base Material of Duct Galvanised Steel minimum thickness 0.8mm
 Cross Joint Fixings 4.8mm dia. steel rivets at 150mm centres or spot welds at 100mm centres. Gasket of FireMaster 607 Paper 15mm wide x 3mm thick or Fenland Fire intumescent tape 15mm wide x 5mm thick
 Longitudinal joints Pittsburgh Lock or Grooved corner (RAS) and flanged cross joints.
 Additional Non- Fire Protection Layers to Duct None
 Detail of Penetration Seal FireMaster Expanding Felt or Offcuts of FastWrap+ packed into gap with covering of Hilti CP601 S mastic. See Drawing FM CAD D-06 for details
 Drawings FM CAD D-01 : General Arrangement of FireMaster FastWrap+ System
 FM CAD D-02: Access Door Insulation
 FM CAD D-03: 2-Sided Ducts - Layout of FireMaster FastWrap+
 FM CAD D-04: 3-Sided Ducts - Layout of FireMaster FastWrap+
 FM CAD D-05: Vertical Ducts - Installation of FireMaster FastWrap+
 FM CAD D-06: Penetration Seal Details
 FM CAD D-07: Fixing Pin layout on underside of ducts > 600mm wide

TABLE 13

System Name

FireMaster FastWrap⁺

Supply Company

Thermal Ceramics

Scope of Use /Type

KITCHEN EXTRACT DUCT / ADD INSULATING LAYER

Fire Assessment Report Number

WF 157967 dated 9 October 2006

Confirm that ductwork system was tested & evaluated to BS 476 Part 24 [ISO 6944] YES

ORIENTATION: Data for horizontal and vertical duct applications												
DUCT SHAPE: Data for rectangular, circular and oval ducts												
Fire Resistance	Longer Side	Thickness of duct	State if any panel stiffening is required	Max Duct Section Length	Cross Joints Section, Type & Size	Max Spacing of Duct Stiffeners	Section Type and Size of Duct Stiffeners	Are Stiffeners or Tie Rods Needed	Maximum Spacing of hangars and bearers	Thickness of Fire Protection Layer	Fire protection material type & product name	Fixing method for fire protection layers
Stability: 120 mins Integrity: 120 mins Insulation: 30 mins	up to 400mm	steel duct 0.8mm	YES	1.51	J3	0.75	S2	Yes	1.51	38mm	FireMaster FastWrap+	Stainless steel bands
Stability: 120 mins Integrity: 120 mins Insulation: 30 mins	401mm to 1000mm	steel duct 0.8mm	YES	1.51	J4	0.75	S3	Yes	1.51	38mm	FireMaster FastWrap+	Stainless steel bands & Anchor Pins on underside of duct where duct width > 400mm
Stability: 120 mins Integrity: 120 mins Insulation: 30 mins	1001mm to 2000mm	steel duct 1.0 mm	YES	1.51	J5	0.75	S5	Yes	1.51	38mm	FireMaster FastWrap+	Stainless steel bands & Anchor Pins on underside of duct where duct width > 400mm
Stability: 120 mins Integrity: 120 mins Insulation: 30 mins	2001mm to 3000mm	steel duct 1.2 mm	YES	1.51	J6	0.625	S6	Yes	1.51	38mm	FireMaster FastWrap+	Stainless steel bands & Anchor Pins on underside of duct where duct width > 400mm

NOTES

Base Material of Duct

Galvanised Steel minimum thickness 0.8mm

Cross Joint Fixings

4.8mm dia. steel rivets at 150mm centres or spot welds at 100mm centres. Gasket of FireMaster 607 Paper 15mm wide x 3mm thick or Fenland Fire intumescent tape 15mm wide x 5mm thick

Longitudinal joints

Pittsburgh Lock or Grooved corner (RAS) and flanged cross joints.

Additional Non- Fire Protection Layers to Duct

None

Detail of Penetration Seal

FireMaster Expanding Felt or Offcuts of FastWrap+ packed into gap with covering of Hilti CP601 S mastic. See Drawing FM CAD D-06 for details

Drawings

FM CAD D-01 : General Arrangement of FireMaster FastWrap+ System

FM CAD D-02: Access Door Insulation

FM CAD D-03: 2-Sided Ducts - Layout of FireMaster FastWrap+

FM CAD D-04: 3-Sided Ducts - Layout of FireMaster FastWrap+

FM CAD D-05: Vertical Ducts - Installation of FireMaster FastWrap+

FM CAD D-06: Penetration Seal Details

FM CAD D-07: Fixing Pin layout on underside of ducts > 600mm wide

TABLE 14

System Name

FireMaster FastWrap⁺

Supply Company

Thermal Ceramics

Scope of Use /Type

KITCHEN EXTRACT DUCT / ADD INSULATING LAYER

Fire Assessment Report Number

WF 157967 dated 9 October 2006

Confirm that ductwork system was tested & evaluated to BS 476 Part 24 [ISO 6944] YES

ORIENTATION: Data for horizontal and vertical duct applications												
DUCT SHAPE: Data for rectangular, circular and oval ducts												
Fire Resistance	Diameter	Thickness of duct	State if any panel stiffening is required	Max Duct Section Length	Cross Joints Section, Type & Size	Max Spacing of Duct Stiffeners	Section Type and Size of Duct Stiffeners	Are Stiffeners or Tie Rods Needed	Maximum Spacing of hangars and bearers	Thickness of Fire Protection Layer	Fire protection material type & product name	Fixing method for fire protection layers
Stability: 120 mins Integrity: 120 mins Insulation: 30 mins	Up to 0.2	steel duct 0.8mm	YES	1.51 straight Seam or 3.0 spiral	Socket & spigot with steel rivets			No	1.51	38mm	FireMaster FastWrap+	Stainless steel bands & Anchor Pins on underside of duct where duct diameter > 200mm & at 300mm centres where bands cannot be fitted
Stability: 120 mins Integrity: 120 mins Insulation: 30 mins	0.201 to 0.5	steel duct 0.8mm	YES	1.51 straight Seam or 3.0 spiral	Spiral Mate			No	1.51	38mm	FireMaster FastWrap+	Stainless steel bands & Anchor Pins on underside of duct where duct diameter > 200mm & at 300mm centres where bands cannot be fitted
Stability: 120 mins Integrity: 120 mins Insulation: 30 mins	0.501 to 0.71	steel duct 1.0 mm	YES	1.51 straight Seam or 3.0 spiral	Spiral Mate or 40mm x 40mm x 5mm RSA			No	1.51	38mm	FireMaster FastWrap+	Stainless steel bands & Anchor Pins on underside of duct where duct diameter > 200mm & at 300mm centres where bands cannot be fitted
Stability: 120 mins Integrity: 120 mins Insulation: 30 mins	0.711 to 1.0	steel duct 1.2 mm	YES	1.51 straight Seam or 3.0 spiral	Spiral Mate or 40mm x 40mm x 5mm RSA	1m	40mm x 40mm x 4mm RSA	Yes	1.51	38mm	FireMaster FastWrap+	Stainless steel bands & Anchor Pins on underside of duct where duct diameter > 200mm & at 300mm centres where bands cannot be fitted
Stability: 120 mins Integrity: 120 mins Insulation: 30 mins	1.001 to 1.25	steel duct 1.2 mm	YES	3.0 spiral	Spiral Mate or 40mm x 40mm x 5mm RSA	1m	50mm x 50mm x 5mm RSA	Yes	1.51	38mm	FireMaster FastWrap+	Stainless steel bands & Anchor Pins on underside of duct where duct diameter > 200mm & at 300mm centres where bands cannot be fitted

NOTES

Base Material of Duct

Galvanised Steel minimum thickness 0.8mm

Cross Joint Fixings

4.8mm dia. steel rivets at 150mm centres or spot welds at 100mm centres. Gasket of FireMaster 607 Paper 15mm wide x 3mm thick or Fenland Fire intumescent tape 15mm wide x 5mm thick

Longitudinal joints

Straight Seam equivalent to Pittsburgh Lock or Spiral Seam equivalent to grooved corner (RAS) used in rectangular ducts

Additional Non- Fire Protection Layers to Duct

None

Detail of Penetration Seal

FireMaster Expanding Felt or Offcuts of FastWrap+ packed into gap with covering of Hilti CP601 S mastic. See Drawing FM CAD D-06 for details

Drawings

FM CAD D-01 : General Arrangement of FireMaster FastWrap+ System

FM CAD D-02: Access Door Insulation

FM CAD D-03: 2-Sided Ducts - Layout of FireMaster FastWrap+

FM CAD D-04: 3-Sided Ducts - Layout of FireMaster FastWrap+

FM CAD D-05: Vertical Ducts - Installation of FireMaster FastWrap+

FM CAD D-06: Penetration Seal Details

FM CAD D-07: Fixing Pin layout on underside of ducts > 600mm wide

TABLE 15

System Name

FireMaster FastWrap⁺

Supply Company

Thermal Ceramics

Scope of Use /Type

KITCHEN EXTRACT DUCT / ADD INSULATING LAYER

Fire Assessment Report Number

WF 157967 dated 9 October 2006

Confirm that ductwork system was tested & evaluated to BS 476 Part 24 [ISO 6944] YES

ORIENTATION: Data for horizontal and vertical duct applications												
DUCT SHAPE: Data for rectangular, circular and oval ducts												
Fire Resistance	Diameter	Thickness of duct	State if any panel stiffening is required	Max Duct Section Length	Cross Joints Section, Type & Size	Max Spacing of Duct Stiffeners	Section Type and Size of Duct Stiffeners	Are Stiffeners or Tie Rods Needed	Spacing of hangers and	Thickness of Fire Protection Layer	Fire protection material type & product name	Fixing method for fire protection layers
Stability: 120 mins Integrity: 120 mins Insulation: 60 mins	Up to 0.2	steel duct 0.8mm	YES	1.51 straight Seam or 3.0 spiral	Socket & spigot with steel rivets			No	1.51	100mm	FireMaster FastWrap+	Stainless steel bands & Anchor Pins on underside of duct where duct diameter > 200mm & at 300mm centres where bands cannot be fitted
Stability: 120 mins Integrity: 120 mins Insulation: 60 mins	0.201 to 0.5	steel duct 0.8mm	YES	1.51 straight Seam or 3.0 spiral	Spiral Mate			No	1.51	100mm	FireMaster FastWrap+	Stainless steel bands & Anchor Pins on underside of duct where duct diameter > 200mm & at 300mm centres where bands cannot be fitted
Stability: 120 mins Integrity: 120 mins Insulation: 60 mins	0.501 to 0.71	steel duct 1.0 mm	YES	1.51 straight Seam or 3.0 spiral	Spiral Mate or 40mm x 40mm x 5mm RSA			No	1.51	100mm	FireMaster FastWrap+	Stainless steel bands & Anchor Pins on underside of duct where duct diameter > 200mm & at 300mm centres where bands cannot be fitted
Stability: 120 mins Integrity: 120 mins Insulation: 60 mins	0.711 to 1.0	steel duct 1.2 mm	YES	1.51 straight Seam or 3.0 spiral	Spiral Mate or 40mm x 40mm x 5mm RSA	1m	40mm x 40mm x 4mm RSA	Yes	1.51	100mm	FireMaster FastWrap+	Stainless steel bands & Anchor Pins on underside of duct where duct diameter > 200mm & at 300mm centres where bands cannot be fitted
Stability: 120 mins Integrity: 120 mins Insulation: 60 mins	1.001 to 1.25	steel duct 1.2 mm	YES	3.0 spiral	Spiral Mate or 40mm x 40mm x 5mm RSA	1m	50mm x 50mm x 5mm RSA	Yes	1.51	100mm	FireMaster FastWrap+	Stainless steel bands & Anchor Pins on underside of duct where duct diameter > 200mm & at 300mm centres where bands cannot be fitted

NOTES

Base Material of Duct

Galvanised Steel minimum thickness 0.8mm

Cross Joint Fixings

4.8mm dia. steel rivets at 150mm centres or spot welds at 100mm centres. Gasket of FireMaster 607 Paper 15mm wide x 3mm thick or Fenland Fire intumescent tape 15mm wide x 5mm thick

Longitudinal joints

Straight Seam equivalent to Pittsburgh Lock or Spiral Seam equivalent to grooved corner (RAS) used in rectangular ducts

Additional Non- Fire Protection Layers to Duct

None

Detail of Penetration Seal

FireMaster Expanding Felt or Offcuts of FastWrap+ packed into gap with covering of Hilti CP601 S mastic. See Drawing FM CAD D-06 for details

Drawings

FM CAD D-01 : General Arrangement of FireMaster FastWrap+ System

FM CAD D-02: Access Door Insulation

FM CAD D-03: 2-Sided Ducts - Layout of FireMaster FastWrap+

FM CAD D-04: 3-Sided Ducts - Layout of FireMaster FastWrap+

FM CAD D-05: Vertical Ducts - Installation of FireMaster FastWrap+

FM CAD D-06: Penetration Seal Details

FM CAD D-07: Fixing Pin layout on underside of ducts > 600mm wide

ULTIMATE™ Protect.

1. Product description

A new generation resin bonded high performance processed mineral wool, also known as U Protect, consists of slab and wired mat solutions, faced on one side with an aluminium foil. Installed onto steel ducts to provide passive fire protection.

2. Manufacturer

Saint-Gobain Isover, Whitehouse Industrial Estate, Runcorn, Cheshire, WA7 3DP.

Telephone/ Fax 01928 796180, www.isover.co.uk

Email: techinsulation@saint-gobain.com

3. Availability

From national distributors.

4. System Types & Cross Section Available

Addition of a **fire protection** layer to steel duct section whether rectangular, circular or oval for horizontal or vertical applications

5 Application Techniques

Steel pin information

The insulation is fixed to the duct using steel pins, 2.7mm to 3mm nominal diameter, and spring steel washers, minimum 30mm diameter. The pins are stud-welded or self-drilling steel pins.

Self-drilling pins

Self-drilling pins (e.g. LENNE IBS1 self-drilling screw pins) or pins that include a steel base plate which fastens to the duct (minimum of two M4 steel self-drilling/ self-tapping screws or two M4 steel rivets, e.g. Big head M5/B23 studs) NB: The length of pin should be equal to the insulation thickness + 3mm.

Horizontal & Vertical rectangular ducts

- Pin fixing positions Distance of the pins to the duct's edges or slab joints: 80mm
- Maximum distance between pins: 260mm

Secure the corner joints with Isover FireProtect screws (at maximum 260mm centres). The screw length must be a minimum 2 x the insulation thickness.

Horizontal circular ducts

No pins required. Using clamping rings, secure the joints of the insulation mats together; or alternatively stitch the mats together with steel thread.

Vertical circular ducts

Vertical installation requires that the insulation mats are to be secured with pins and washers. Place ≥ 2.7 mm diameter pins and ≥ 30 mm washers in two rows around the duct with centres ≤ 200 mm, at 100 mm distance from the mat joint. Using clamping rings, secure the joints of the insulation mats together; or alternatively stitch the mats together with steel thread.

Glue. No glue is required except at the penetration.

Penetration Details

Using the same insulation being used for the rest of the duct, fully pack the space between the duct and the partition. Ensure tight compression in order to completely fill the opening. Using a spatula apply a ~2mm thick layer of Isover Protect BSF intumescent to **BOTH** sides of the construction, to

seal the joint. Fix an L-profile (30x30x3) around the duct on both sides of the construction with steel rivets. Using two steel screws for each side ensure the top and bottom profiles are fixed to the construction. Glue the ends of the insulation to the penetration using Isover Protect BSK Adhesive (thickness ~2mm).

Minimum thickness of underlying steel duct: minimum 0.7mm

Available insulation thickness: 60mm to 120mm.

6. Steel/ Duct preparation requirements. Refer to table items 1-4.

7. Additional mechanical fixing. Refer to table items 1-4.

8. Nominal density. 66kg/m³

9. Thickness Range. Available insulation thickness: 60mm to 120mm.

10. Fire resistance range to BS 476 Part 24

	Maximum duration (hrs)	
	Stability & Integrity	Insulation
Ventilation Duct (BS476-24 Type A + B)	2	2
Smoke Extract Duct (BS476-24 Type A + B)	2	2

11. Constraints for fire resistance. For vertical and horizontal rectangular and circular ductwork

(1) Ventilation Ductwork

(2) Smoke Extract Ductwork

12. Appearance

Bright aluminium foil faced, yellow mineral wool.

13. On site use

See table and notes.

14. Third Party Certification

ULTIMATE™ products are manufactured by Saint-Gobain Isover, operating at the highest standards of testing, approval and assessment by third parties such as. Warringtonfire, FIW, VDI. Our solution is also tested and approved to EN1366-1 for Ventilation Ductwork.

Exova Warringtonfire report 176396A Issue 3

Exova Warringtonfire report 176396B issue 2

15. Durability

ULTIMATE™ is water repellent, rot proof, chemically inert, does not support fungal or bacterial growth and does not encourage vermin.

16. Quality Assurance to DIN EN ISO 9001 and environmental standards to DIN EN ISO 14001

17. Performance to other British and European Standards

To EN1366-1 for up to 2 hours vertical and horizontal rectangular and circular ductwork

18. Other applications

Marine, High Temperature and acoustic insulation.

Reaction to fire A1 classification as defined in BS EN 13501:1.

Non-combustible and Class O, as defined in Approved Document B of Building Regulations and BS EN 9999:2008.

TABLE 1**System name:** ULTIMATE™ Protect**Manufacturer:** Saint-Gobain Isover**Fire resisting duct: scope of use/type:** Ventilation and Smoke Extract Fire protection cladding to steel ducts**Fire Assessment Report number:** Exova Warringtonfire report 176396A Issue 2 & Exova Warringtonfire report 176396B Issue 2

Confirm that the Ductwork system was tested and evaluated to BS 476 Part 24 [ISO 6944]: Yes

Orientation: Horizontal and vertical duct applications

Duct Shape: Rectangular, circular and oval ducts

Fire resistance; (a) Stability (b) Integrity (c) Insulation	Maximum duct size (width x height)	Thickness of duct: (a) steel (b) board (c) coating	State if panel stiffening is required	Max duct section length	State type of cross joints, section type and size	Maximum spacing of duct stiffeners	Section type and size of duct stiffeners	Are stiffeners or tie rods needed?	Maximum spacing of hangers and bearers	Thickness of fire protection layer	Fire protection material type and product name	Fixing method for fire protection layers
minutes	mm	mm	Yes/no	mm	mm	mm	mm	Yes/no	mm	mm		
Up to 60 (a,b,c)	Side: 2000 Dia: 1250	(a) min 0.7 (see note 5) (b) min 60 (see note 6) (c) n/a	Yes, when required by DW144	1250m m (rect) 3000m m (circ)	DW144, J3 and above (see note 2)	See DW144, Sections 10.5.1, 10.5.2	See DW144, Figs 18-23. (See note 13)	Yes (see note 12)	1250 (rect.) 1200 (circ)	60mm for rectangular 75mm for circular (see note 6)	ULTIMATE™ Protect or U Protect Slab 4.0 Alu1 and Wired Mat 4.0 Alu1	See drawings below and notes 10 & 11
Up to 120 (a,b,c)	Side: 2000 Dia: 1250	(a) min 0.7 (see note 5) (b) min 80 (see note 7, 8 & 9) (c) n/a	Yes, when required by DW144	1250m m (rect) 3000m m (circ)	DW144, J3 and above (see note 2)	See DW144, Sections 10.5.1, 10.5.2	See DW144, Figs 18-23. (See note 13)	Yes (see note 12)	1250 (rect.) 1200 (circ)	80mm for rectangular (see note 8&9) 100mm for circular (see note 7)	ULTIMATE™ Protect or U Protect Slab 4.0 Alu1 and Wired Mat 4.0 Alu1	See drawings below and notes 10 & 11

NOTES

1. Base material of the primary duct: hot-dipped galvanised steel, mild steel or stainless steel. When using stainless steel a greater allowance for thermal expansion must be built into the ductwork construction.
2. Cross joint fixings/centres/and seals:
For rectangular ducts, Use J3 and above at maximum 1250mm centres, as per DW144. At each cross joint Lindab flanges or equivalent, (minimum size 30mmx30mmx1.2mm thick) are fastened to the duct with spot welds at 150mm nominal centres. The flanges are fitted with steel corner plates, (minimum 95mmx95mmx2.5mm thick), slot these

into the flanges at each corner and bolt them together with an M10 steel nut and bolt at each corner. Fasten the flanges together with 40mm steel clamps at 265mm maximum centres. See Figure 3 below. Use a ceramic tape gasket (20mm wide x 3mm thick) between the flanges to seal the joints.

For circular ducts, Lindab or equivalent NPU sleeves, minimum size 100mm x 1,2mm thick, are fastened to the duct, as per DW144 Section 14. Fit a sealing strip of EPDM rubber and a ceramic tape gasket, 15mm wide x 3mm thick, between the sleeve and the duct, on both sides of the joint, to seal the joints.

3. Longitudinal joint must be Pittsburgh lock or grooved corner (RAS) longitudinal seams- see DW144 (1998), Fig 2 and Fig 3.
4. Detail of seal at duct penetration through fire resisting walls or floors- see drawings below and refer to manufacturers instructions:
Rectangular-Place the duct in the penetration, with a ≤ 50 mm gap between the duct and the reveal of the wall or floor opening. A stiffener (steel tube) should be fitted to the duct where the duct passes through the wall or floor penetration. U Protect Slab is used to fully pack the space between the duct and wall or floor. Using a spatula apply a ~ 2 mm thick layer of Isover Protect BSF Intumescent Paint to BOTH sides of the construction, to seal the joint. Fix an L-profile (30x30x3) around the duct on both sides of the construction with steel rivets.

Circular- follow the same steps as per rectangular but using U Protect Wired Mat. Note that Stiffeners are not used with circular ducts

Screw a suspension bracket (30mmx2mm) to the duct on both sides of the construction. Fix long L-profiles (30mmx30mmx3mm) above and below the bracket with one rivet each (4mmx13mm). Fix short L-profiles (30mmx30mmx3mm) are fixed with nuts and bolts (M8) to the bracket eye. Glue the ends of the insulation to the construction using Isover Protect BSK adhesive (thickness ~ 2 mm) This last instruction applies to both rectangular and circular ducts.
5. Thickness of steel is a minimum of 0.7mm, up to 1.0mm, affecting the maximum duct size. Further guidance given in the manufacturers instructions and the HVCA document DW144.
6. 60mm is related to rectangular ductwork only.
Exception.....80mm is required for rectangular vertical Type B (fire inside) ductwork.

Exception.....For circular ductwork, 75mm is the available thickness for 60 mins stability, integrity and insulation
7. 80mm is related to horizontal rectangular ductwork only (not smoke extract scenario as in note 8).
For Type A horizontal & vertical circular ductwork, 100mm is the available thickness for 120 mins stability, integrity and insulation.

For Type B vertical and smoke extract circular ductwork, 120mm is the available thickness for 120 mins stability, integrity and insulation.
8. Smoke extract for rectangular horizontal ductwork requires a thickness of 90mm, for 120 mins stability, integrity and insulation
9. Type B (fire inside) rectangular vertical ductwork requires a thickness of 100mm, for 120 mins stability, integrity and insulation
10. For rectangular ducts, Fireprotect Screws are used to secure the corner joints of the slabs, at 260mm centres. The screw must be at least twice the insulation thickness.
For horizontal circular ducts, use clamping rings to secure the joints of the insulation mats together; or alternatively stitch the mats together with steel thread. There is no need to cut the insulation at the duct joint due to the flexibility of the insulation. For Vertical circular ducts The wired mats are to be secured with pins and washers. Place ≥ 2.7 mm diameter pins and ≥ 30 mm washers in two rows around the duct with centres ≤ 200 mm, at 100 mm distance from the mat joint. Using clamping rings, secure the joints of the insulation mats together; or alternatively stitch the mats together with steel thread
11. For rectangular ducts, 2 simple rules apply: Distance of the pins to the duct's edges or slab joints: 80mm Maximum. Maximum distance between pins: 260mm in all directions.
Steel Pin Specification: The insulation is fixed to the duct using steel pins, 2.7mm to 3mm nominal diameter, and spring steel washers, minimum 30mm diameter. The pins are stud-welded or screwed to the duct. If the screwed pins are selected, these are either; Self-drilling pins (e.g. LENNE IBS1 self-drilling screw pins) or pins that include a steel base plate which fastens to the duct (minimum of two M4 steel self-drilling/self-tapping screws or two M4 steel rivets, e.g. Big head M5/B23 studs) NB: The length of pin should be equal to the insulation thickness + 3mm
12. For rectangular ducts, attach internal steel stiffeners at a 90° angle to any side of the duct section where the width or depth exceeds 500mm. Position these at midwidth/ depth and mid-length in each duct section. Each internal stiffener should consist of a steel tube (16mm diameter x 2mm thick). Fasten the stiffeners to the duct walls with a

steel washer of the same size, on the outside of the duct wall. Use 72mm diameter x 1mm thick washers to fasten the stiffener, on the inside with M6 steel bolts.

13. External Stiffening of Rectangular Ductwork: If the longer side of the duct is greater than 1500mm, and the ducts have a section length greater than 625mm, then a stiffening collar is required. See DW144 for further details. Circular- Where 120 minutes of fire resistance is required for steel ducts, 40mmx5mm steel flanges should be positioned approx. 10mm from each duct connection.

Figure 3 - Rectangular duct joints

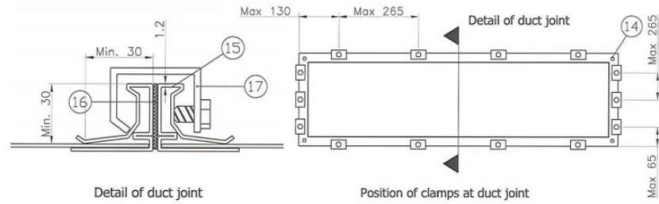

Step 4a: Reinforcing a rectangular duct



Step 4b: Reinforcing a circular duct

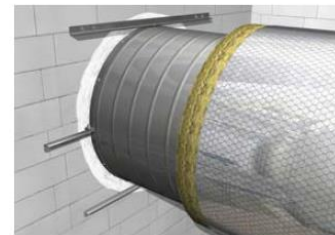

Horizontal and vertical rectangular ducts

- Secure the corner joints with Isover FireProtect Screws (3 screws per side at 300mm centres). The screw length must be 2 x the insulation thickness.

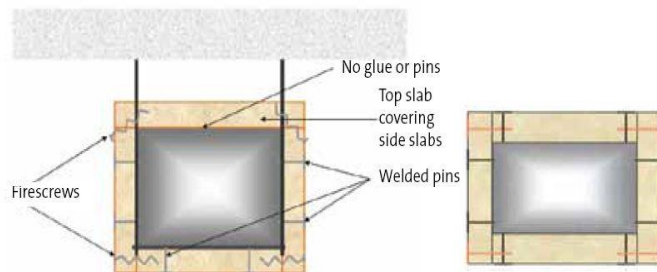

ULTIMATE™ Protect slab, FireProtect Screw and pin position for horizontal ducts

ULTIMATE™ Protect slab, FireProtect Screw and pin position for vertical ducts

Underside slabs (note the side slabs are omitted)

Example of pin positions and FireProtect Screw positions



Side slabs (note the top slab is omitted)

Example shows overlapping of the side slabs onto the underside slabs

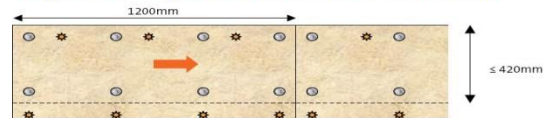

Key

- = Pins
- ★ = FireProtect Screw

NB: No glue or pins are used to fix the top slab. These are only fixed with the use of FireProtect Screws, (shown above as the top row).

Rectangular vertical ducts

Example of pin positions and FireProtect Screw positions
Overlapping on main duct face is shown

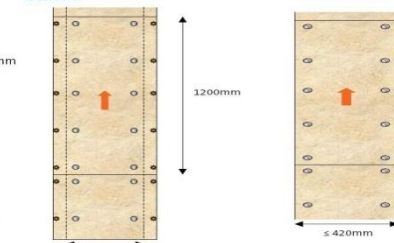

≤ 420mm & Wool thickness ≤ 90mm
or
≤ 400mm & Wool thickness = 100mm

- For rectangular vertical ducts, apply the largest board to the longest side leaving an overlap equivalent to the thickness of the U Protect slab, on either side of the duct
- Repeat for the other side, then place the smaller boards between the overlaps created from the first two steps

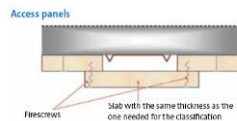

The ULTIMATE™ Protect insulation slabs can

Overlap the opening (see below), or can have a Stepped perimeter.

The pigtail screw type of fixing can be used, provided that it is capable of being used repeatedly. Alternatively the fixings can penetrate through the fixed insulation to the steel duct.

Two or three sided ducts

- Isover Protect BSK Adhesive is to be used between the insulation slab edges and the soffit.
- If the gap between the duct and soffit is less than 50mm, no additional fixtures are needed.
- For larger distances (up to 100mm), a metal angle 50mm x 50mm x 1.2mm should be fitted internally and fixed to the slab with a proprietary metal fixing at max. 300mm centres.
- Additional Stud Welded Pins or Self-Drilling Pins should be fixed to the metal angle at the required centres

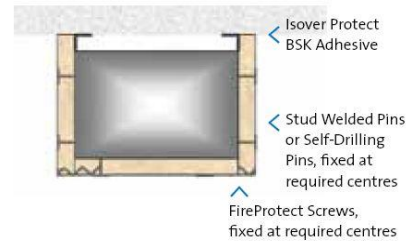
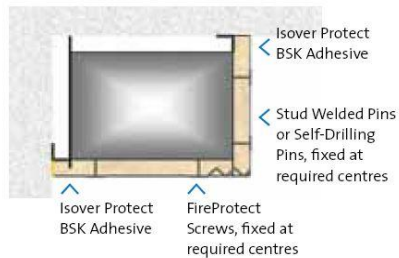

Circular Ducts

Step 4b: Reinforcing a circular duct

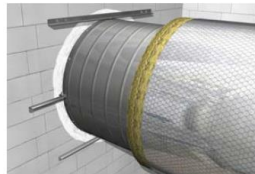

Penetration seal to a riser

Suspension System

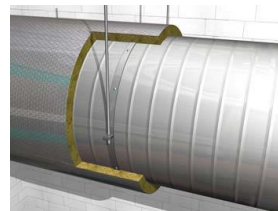

Penetration assembly

